

# Equestrian Vaulting USA

## 2024 RULE BOOK

Equestrian Vaulting USA is a member of the  
United States Equestrian Federation.

THE MOST CURRENT ONLINE  
VERSION OF THIS RULE BOOK SUPERSEDES  
ALL PREVIOUS EDITIONS

Constitution,  
By-Laws &  
Standing Rules



*(Rule Book updated 12/8/2023)*

Equestrian Vaulting USA  
1443 E. Washington Blvd, # 289  
Pasadena, CA 91104  
Phone: 323/654-0800, Fax: 323/654-4306  
Email: [office@equestrianvaulting.org](mailto:office@equestrianvaulting.org)

Visit [www.equestrianvaulting.org](http://www.equestrianvaulting.org) for current rules, more  
information and contacts.

Copyright© 2024 by the Equestrian Vaulting USA.  
All rights reserved. Reproduction without permission is strictly prohibited.

CONSTITUTION	4
MISSION	4
PURPOSE	4
BYLAWS	4
ARTICLE I – MEMBERSHIP	4
ARTICLE II – REGIONS	6
ARTICLE III – BOARD OF DIRECTORS	6
ARTICLE IV – OFFICERS	7
ARTICLE V – COMMITTEES	8
ARTICLE VI – CONFLICT OF INTEREST AND DUALITY OF INTEREST	9
ARTICLE VII – ELECTIONS AND VOTING	9
ARTICLE VIII – MEETINGS	9
ARTICLE IX – NATIONAL OFFICE	10
ARTICLE X – SEAL	10
ARTICLE XI – COMPENSATION	10
ARTICLE XII – AMENDMENTS	10
ARTICLE XIII – DISSOLUTION	10
ARTICLE XIV – PARLIAMENTARY AUTHORITY	10
STANDING RULES	12
SECTION I - MEMBERSHIP	12
SECTION II - VICE-PRESIDENTS	14
SECTION III - COMMITTEES – GENERAL RULES	14
SECTION IV - NOMINATIONS AND ELECTIONS	14
SECTION V - REGIONS	15
SECTION VI - MEETINGS	16
SECTION VII - NATIONAL CHAMPIONSHIPS	16
SECTION VIII - RECOGNIZED COMPETITIONS	16
SECTION IX - MEDAL EXAMINATIONS	20

SECTION X - JUDGES PROGRAM	22
SECTION XI - PROTESTS & GRIEVANCES	23
BARREL SPECIFICATIONS	24

# CONSTITUTION

The name of the corporation shall be the American Vaulting Association, doing business as Equestrian Vaulting USA, Inc. (EVUSA).

## MISSION

The mission of the EVUSA is to expand the recognition and accessibility of the sport of Equestrian Vaulting.

## PURPOSE

The purpose of the EVUSA shall be to provide the infrastructure to support and expand the sport of equestrian vaulting. This shall include:

1. To promote interest in equestrian vaulting — the art of gymnastics/ dance on the back of a moving horse.
2. To educate and inform members and the general public through a variety of print and electronic media.
3. To make and provide resources for study and training.
4. To sponsor clinics, forums and workshops for the training of vaulters, coaches, lungers, horses and judges.
5. To establish rules for recognized competitions.
6. To license judges.
7. To oversee the management of the national championships.
8. To establish standards for achievement awards.
9. To maintain records of the sport for the use of its members.
10. To perform other educational and administrative functions to assist in the promotion and development of the sport.

Any questions, corrections or proposed changes to the EVUSA By-laws or Standing Rules should be sent to the Executive Board, care of the General Secretary of the Association at [generalsecretary@equestrianvaulting.org](mailto:generalsecretary@equestrianvaulting.org).

### **Equestrian Vaulting USA**

1443 E Washington Blvd #289, Pasadena, CA 91104

Email: [info@equestrianvaulting.org](mailto:info@equestrianvaulting.org), Ph: 323-654-0800, Fx: 323-654-4306

[www.equestrianvaulting.org](http://www.equestrianvaulting.org)

Visit [www.usef.org](http://www.usef.org) for the United States Equestrian Federation Rule Book, including current USEF Rules for Vaulting online. USEF, 4001 Wing Commander Way, Lexington, KY 40511

Phone: 859-258-2472, Fax: 859-231-6662

Visit [www.fei.org](http://www.fei.org) for the current FEI International Vaulting Rules online.

# BYLAWS

The Bylaws are the rules adopted by the association chiefly for the governance of its members and the regulation of its affairs. Bylaws must be approved by the members of the association and govern the general organization of the association. Bylaws include rules concerning the categories of membership, election of directors, organization of the association, and amendment of existing Bylaws.

## ARTICLE I — MEMBERSHIP

(see Standing Rules, Section I, Membership for more information)

**Section 1.** There shall be three classes of membership: Club Membership, Individual Membership, and Family Membership. All membership, with the exception of Life Members (see Article I, Section 4.c, and Standing Rules Section I.B.2), must pay annual dues to the EVUSA in order to remain current. Life members shall pay a one-time fee to the EVUSA.

**Section 2.** The Board of Directors, or the Treasurer acting subject to the oversight of the Board of Directors, may revoke and/or may decline to accept annual dues of any Member of the EVUSA who does not conform to such regulations and requirements as shall from time to time be adopted by the Board of Directors.

**Section 3.** There are two categories of Club Membership: Regular and Recreational.

- a. **Regular Club Membership** is for the registration of recognized Clubs who have paid their annual dues and assessments. Club membership is a group membership which includes individuals who participate in competitions, medals tests, and competition awards and has no vote as a Club, nor do its members as individuals, under this category. The EVUSA shall recognize, as member clubs, vaulting clubs which conform to such regulations and requirements as shall from time to time be adopted by the Board of Directors.
- b. **Recreational Club Membership** is for organizations interested in recreational vaulting, who have paid their annual dues. Recreational Club Membership is a group membership which has no vote as a club, nor do its members as individuals, under this category. With a payment of a non-member fee, vaulters may compete in EVUSA Recognized Competitions and may receive EVUSA Novice Pins.

**Section 4.** There are four categories of Individual Membership: Youth, Adult, Life, and Associate. Life members have the rights defined below based on their age. Individual members may register as members of a Club or as Independents. Individual Members who are members of a Registered Club must register as members of that Club (see Article I, Section 3.a.).

- a. **Youth Membership** is for individuals, including competitors, coaches and lungers, under 18 years of age. Youth Members have no vote. Youth Members in good standing shall be eligible to:
  - i. Compete in EVUSA Recognized Competitions
  - ii. Receive EVUSA medals, certificates and other awards
  - iii. Attend EVUSA sponsored educational clinics and seminars
  - iv. Attend all official EVUSA functions
- b. **Adult Membership** is for individuals, including competitors, coaches and lungers, 18 years of age or older. Age is based on age as of January 1 of the calendar year. Adult Members in good standing shall be eligible to:
  - i. Compete in EVUSA Recognized Competitions
  - ii. Receive EVUSA medals, certificates and other awards
  - iii. Attend EVUSA sponsored educational clinics and seminars
  - iv. Attend all official EVUSA functions
  - v. Vote in all EVUSA Elections
  - vi. Serve as members of the Board of Directors
  - vii. Hold Office
- c. **Life members** are Individual Members who have paid the appropriate fee as established by the Board of Directors and who will be subject to no further dues during their lifetimes. Life members in good standing are eligible to the benefits defined in paragraph a. or b. consistent with the member's age as defined in Article I. Section 4.b.
- d. **Associate membership** is a special category established in order to promote membership and involvement in the association. Associate memberships may be listed and promoted under a variety of names as determined by the Executive Board from time to time in order to target particular interest groups. Associate memberships may not vote, compete, serve on the Board of Directors, or hold office in the Association. The Executive Board shall determine the membership fees and benefits for Associate Members.

**Section 5. Family membership** is a group membership which shall consist of a maximum of two adults, plus immediate family members who are under the age of 21 and living in the same household who have paid their annual dues. Family Members 18 years of age or older are Adult Members; Family Members under the age of 18 are Youth Members. All Family members in good standing shall be entitled to:

- i. Compete in EVUSA Recognized Competitions
- ii. Receive EVUSA medals, certificates and other awards
- iii. Attend EVUSA sponsored educational clinics and seminars
- iv. Attend all official EVUSA functions

Each Adult Family Member shall be entitled to:

- i. One vote in all EVUSA Elections
- ii. Serve as members of the Board of Directors
- iii. Hold Office

## **ARTICLE II — REGIONS**

(See Standing Rules, Section V, Regions for more information)

**Section 1.** An EVUSA Region is a geographically defined area with its own internal financial and administrative structure and representation on the EVUSA Board of Directors. Internal structure of EVUSA Regions is in harmony with EVUSA Constitution and Bylaws.

**Section 2.** Regional boundaries shall be established by the Board of Directors based on geographical areas, not to exceed twelve (12) Regions.

**Section 3.** The Board of Directors shall periodically review the Region boundaries and revise the boundaries, if necessary, to ensure they meet the needs of the association.

## **ARTICLE III — BOARD OF DIRECTORS**

(see Standing Rules, Section II, Vice Presidents for more information)

**Section 1.** The number of Directors shall not be less than fifteen (15) nor more than thirty-nine (39). At each official election, the number shall be determined by the Board of Directors, prior to the election. The Board shall, from time to time, determine roles and position descriptions for Directors, and nominees shall be nominated specifically for each Director position. The nominee for each Director position who receives the highest number of votes shall be elected to that Position. Regional Supervisors, duly elected by the Region or approved by the Board of Directors, shall be members of the Board of Directors.

**Section 2.** Directors shall serve two-year terms, beginning January 1st of the year following the election. One half of the directors shall be elected each year, to insure a rotating Board as well as continuity.

**Section 3.** Directors of the Board, Executive Officers, and Regional Supervisors (elected officials) shall be elected from eligible Individual Members in good standing and shall maintain a current EVUSA Membership while serving in an elected capacity, participating in a Board Meeting or conducting the business of the Association. Any elected official failing to maintain a current EVUSA Membership may not participate in Board meetings and/or other Association business until the EVUSA membership is brought current.

**Section 4.** At all meetings of the Board of Directors, one-third of its members shall constitute a quorum. Directors shall, in case of absence from the meeting, wherever possible, communicate their positions in writing on the basis of the advanced agenda. Comments received by the EVUSA General Secretary in advance of a Board of Directors meeting will be distributed to all participants in the meeting. Regardless of the number of positions held by any individual serving on the Board (i.e. Board Member and Regional Supervisor; Board Member and Officer) no individual will be counted more than once toward the quorum and no individual has more than one vote on the Board of Directors.

**Section 5.** The Board of Directors shall manage the affairs of the Association and may authorize or review contracts to be made by officers of the Association. Directors shall approve an annual budget. Directors shall establish annual membership dues by three-quarter vote of all directors. The Directors shall be charged with the responsibility of fulfilling to the greatest extent possible the purposes of this Association.

**Section 6.** The Board of Directors shall encourage and maintain open communication with the members in matters concerning the Association. The Board shall consult the members on any matters which, in its judgment, require the action of the general membership. The Board is subject to the orders of the Association, and none of its acts shall conflict with actions taken by the Association.

**Section 7.** Violations of rules will be dealt with on an individual basis, and the Board of Directors reserves the right to impose fines, probations, suspensions or censures after mutual attempts have been made at an equitable solution.

**Section 8.** The final contract between the National Office Manager and the EVUSA shall be approved by the Executive Board.

**Section 9.** The President, with approval of the Executive Board, shall invite the President of the Youth Ambassador program to serve as a nonvoting advisor to the Board of Directors. This appointment shall be made annually.

## **ARTICLE IV — OFFICERS**

(see Standing Rules, Section II, Vice Presidents for more information)

**Section 1. Elected Officers.** The elected officers of the Association shall be President, Executive Vice President, General Secretary and Treasurer. These officers shall be elected biennially by simple majority vote of the Membership at each appropriate general election of the Association. The elected officers shall be members of the Board of Directors. The officers shall hold office during the ensuing two years, until their successors are installed at the first Board of Directors meeting following the election. The President and General Secretary shall be elected in even numbered years; the Executive Vice President and Treasurer shall be elected in odd numbered years. In order to be nominated and run for an Officer position, members must meet the following prerequisites:

- a. President, Executive Vice President, Treasurer- Must have completed one full term as a member of the Board of Directors.
- b. General Secretary- Must have attended at least one Board meeting and served successfully on one National level committee.

**Section 2. Executive Board.** The Executive Board shall consist of the President, Executive Vice President, General Secretary, Treasurer and such Vice Presidents as may from time to time be determined by the Board of Directors. The immediate Past-President and Technical Advisor shall serve in an advisory capacity to the Executive Board. The Executive Board shall have the power to transact all business of the Association between meetings of the Board of Directors and to make contracts in the name of or on behalf of the EVUSA. Contracts may only be entered into by direction of the Executive Board. One-half of the voting members shall constitute a quorum.

**Section 3. President.** The President shall be the chief executive officer of the Association.

- a. The President, with the Executive Vice President or General Secretary, shall sign all contracts and obligations of the Association and perform such other duties as may be assigned to him by the Board of Directors.
- b. The President shall appoint all committee chairmen with the approval of the Executive Board. He shall be a member of all committees.
- c. The President may, at any time, call a meeting of the Board of Directors and must do so at the request of eight (8) Directors, notice of such meeting to be given at least three (3) weeks prior to the meeting date.
- d. The President, with the approval of the Executive Board, may fill by appointment any vacancies in Officer positions that occur during a term. The appointee shall serve until the next scheduled election of the Association for that position, at which time the vacancy will be filled by election to serve the balance of the unexpired term.
- e. The President, after consultation with the affected Region, may fill by appointment any vacancies in Regional Supervisor positions that occur during a term. The appointee shall serve until the next general election of the Association at which time the vacancy will be filled by election to serve the balance of the unexpired term.

**Section 4. Executive Vice President.** The Executive Vice President shall provide oversight of and guidance to the National Office; shall assure that duties of and assignments to the National Office are completed within the defined standards of performance and shall assist with resolution of problems involving the National Office. In the absence of the President, the Executive Vice President shall exercise any power or duty of the President. In

case of the resignation, removal or death of the President, the Executive Vice President automatically becomes President until the next regular election of officers.

**Section 5. General Secretary.** The General Secretary shall give notice to the members of the Board of Directors of all meetings; shall send out, in advance, the agendas prepared by the President to the Directors, Executive Board and others concerned at least ten (10) days prior to the meeting date.

He shall take minutes of the meetings; shall distribute immediately following a summary of the minutes to the Board of Directors, Executive Board and others concerned; and shall attend to other matters pertaining to meeting procedures as directed by the President and attend to all Presidential correspondence of the Association. He shall perform such other duties as may be assigned him by the President.

**Section 6. The Treasurer.** The Treasurer shall keep an accurate record of the receipts and disbursements authorized by the Board of Directors; shall prepare an Annual Budget; shall present a statement of account at every meeting of the Board of Directors; and shall have the account ready and available for inspection upon request of the Board. The books of the Association shall be inspected annually by a person(s) appointed by the Board of Directors.

**Section 7. The Technical Advisor.** The President, with approval of the Board of Directors, shall appoint a Technical Advisor. The Technical Advisor shall be appointed annually. The Technical Advisor shall act in an advisory capacity to the Association and to the Executive Board. He shall advise the Association in matters of correct procedures, rules and technicalities concerning the sport and shall concern himself with what is going on in the sport in other parts of the world. He shall guide the membership toward the goals and purposes of the Society. The Technical Advisor does not have a vote on either the Executive Board or the Board of Directors except as elected as a Director or Officer.

**Section 8.** The President, Executive Vice President, Treasurer and/or National Office Manager shall have the authority to sign checks of the Association in amounts not to exceed the budgeted amounts approved by the Board of Directors.

**Section 9.** Any officer may resign by written resignation to take effect upon acceptance by the Board of Directors. The Board of Directors may remove, by not less than a majority of the full membership of the Board of Directors, any officer.

**Section 10.** Members shall, in case of absence at a meeting, wherever possible, communicate their positions in writing on the basis of the advanced agenda.

## ARTICLE V — COMMITTEES

(see Standing Rules, Section III, Committees for more information)

**Section 1.** There shall be such standing and temporary committees as are deemed necessary to carry on the work of the Association.

**Section 2.** Standing committees must include:

- a. **Grievance Committee** - A Grievance Committee, composed of no fewer than five (5) Individual Members, will be elected each year at the Annual Meeting of the Membership. No member of the Executive Board may serve on this Committee. Any given club may be represented by only one (1) member on this Committee. At least four (4) Regions must be represented. This Committee shall elect a chairman from its members.

**Section 3.** Temporary and Other Committees:

- a. All other committees shall be established by the President. All committees are subject to the orders of the Board of Directors, and none of their acts shall conflict with actions taken by the Board of Directors.
- b. Committee Chairmen are appointed by and serve at the pleasure of the President, with the approval of the Executive Board.



## ARTICLE VI — CONFLICT OF INTEREST AND DUALITY OF INTEREST

**Section 1.** Generally. If any Officer, Director or member of any other committee has a financial interest in any contract or transaction involving the Association, such individual shall not participate in the evaluation or approval of such contract or transaction unless the material facts of the relationship or interest are disclosed or known to the other Officers, Directors, or other committee members, but he or she shall be counted in determining the quorum for the meeting relating to the matter. If such disclosure is made, the contracts or transaction shall not be voidable if the Officers, Directors, or committee members in good faith authorized the contracts or transaction by the affirmative vote of the majority of the disinterested Officers, Directors, or committee members and the contract or transaction is fair to the Association at the time it is authorized.

**Section 2.** Duality of Interest. Any duality of interest on the part of any Director shall be disclosed to the Board of Directors, and made a matter of record through an annual procedure and also when the interest becomes a matter of Board action. Any Director having a duality of interest shall not vote or use his or her personal influence on the matter, but he or she shall be counted in determining the quorum for the meeting relating to the matter for which the duality exists. The minutes of the meeting shall reflect that a disclosure was made, the Director abstained from voting, and a quorum was present with the inclusion of the affected Director. Any new Director will be advised of this policy upon entering the duties of his or her office.

**Section 3.** Conflict of Interest Policy. The Board of Directors shall adopt a Conflict of Interest Policy including minimizing conflict of interest situations regarding the selection of athletes, horses, coaches, trainers, managers, administrators, veterinarians, officials and others for competitions. All Officers, Board members, Committee members, staff, and other volunteers as determined by the Board of Directors shall be required to sign the policy before taking office or assuming their duties.

## ARTICLE VII — ELECTIONS AND VOTING

(Refer to Standing Rules: Section IV, Nominations and Elections for further election guidelines)

**Section 1.** Adult Members in good standing shall be entitled to one vote.

**Section 2.** Voting method for Directors, Officers and Regional Supervisors may be determined or changed by the Board of Directors each year, provided that the method selected does not jeopardize voting anonymity, the ability for members to vote from their home, and provides a written record of results.

**Section 3.** Nomination of the Board of Directors, Officers and Regional Supervisors:

- a. At the appropriate time, the General Secretary shall notify the membership that nominations are open for the Director, Officer and Regional Supervisor positions to be elected that year.
- b. Any eligible member may self-nominate for any position for which they are qualified.
- c. The General Secretary shall provide questionnaires to all nominated candidates which must be completed in order to be eligible for election.

**Section 4.** Election Procedures:

- a. The National Office Manager shall prepare the ballot of Nominees as provided by the General Secretary. The National Office Manager shall distribute the ballot as provided for in the Standing Rules, Section IV.

## ARTICLE VIII — MEETINGS

(see Standing Rules, Section VI, Meetings for more information)

**Section 1.** There shall be one Annual Meeting of the Association in each year in such month and on such day, time and place as the Executive Board may designate. The business at annual meetings shall include, at least, the

Report of the Treasurer, Reports of the Board of Directors and of Committees, and appointment of the Grievance Committee.

**Section 2.** The President shall have the power to call a meeting of the Association at any time, and must call a meeting when requested in writing to do so by any eight (8) members of the Board of Directors or by two-thirds of the eligible Individual members of the Association. Written notice of such meeting must be given to all members at least three (3) weeks prior to the meeting.

## **ARTICLE IX — NATIONAL OFFICE**

**Section 1.** A National Office Manager shall maintain permanent files of the Association, prepare and mail the ballots for all official elections, attend to member and outside correspondence, maintain all membership and other records, pay bills, issue and co-sign checks, attend to bookkeeping tasks of the Association, be custodian of the Seal of the Association, and attend to any other administrative tasks as directed by the Board of Directors.

## **ARTICLE X — SEAL**

**Section 1.** The Seal of the Association shall be in the form of a circle and shall bear the name of the Association, the name of the State in which it was incorporated, the year of its incorporation and the words “Corporate Seal”

## **ARTICLE XI — COMPENSATION**

Directors and Officers shall not receive any compensation for their services on the Board of Directors, however, the corporation may purchase and maintain insurance on behalf of any such person against any liability asserted against and incurred by such person in any such capacity or arising out of his status as such (commonly referred to as “Directors and Officers Insurance”). The preceding shall not prevent the Board of Directors from providing reasonable compensation to a director for services which are beyond the scope of his or her duties as director or from reimbursing any director for expenses actually and necessarily incurred in the performance of his or her duties as a director.

## **ARTICLE XII — AMENDMENTS**

**Section 1.** This Constitution and Bylaws may be added to, altered or amended by a favorable vote of not less than two-thirds of the responding eligible Individual Members at a General Meeting of the Association or by mail.

**Section 2.** At any meeting of the Board of Directors at which a quorum is present, or at a General Meeting of the Membership, the Standing Rules of the Association may be added to, suspended, modified or rescinded by a majority vote, only after prior written notice is provided by way of identification in the meeting agenda or a special notice to Board members at least three (3) weeks in advance. A majority vote by mail of the Board of Directors is acceptable.

## **ARTICLE XIII — DISSOLUTION**

**Section 1.** If at any time the Association dissolves, any funds remaining in the treasury shall be distributed directly to the United States Pony Clubs, Inc.

## **ARTICLE XIV — PARLIAMENTARY AUTHORITY**

*Robert’s Rules of Order Revised* shall govern meetings of the Association when not in conflict with these Bylaws. *Robert’s Rules of Order Revised* may be used as a guide to conducting the business of the Association for situations that are not specifically addressed by the Bylaws and Standing Rules.



# STANDING RULES

The Standing Rules are the rules and standards for the conduct of the business of the Association. Standing Rules are approved by the Board of Directors. *Robert's Rules of Order Revised* shall be used as a guide to conducting the business of the Association for situations that are not specifically addressed by the Bylaws and Standing Rules.

## SECTION I - MEMBERSHIP

### A. General Information

1. Yearly memberships are valid January 1 through December 31 of each year.
2. Memberships paid between September 1 and December 31 of any year are valid through December 31 of the following year. Voting privileges become effective January 1 of the membership year.
3. Memberships must be renewed by January 1 of each year in order to remain current.
4. In order for memberships to be valid, both fees and membership forms (with all required information) must be received by the National Office, electronically or by mail.
5. All fees must be paid in U.S. funds.
6. Any checks payable to the EVUSA or any agent acting on behalf of the EVUSA refused by the bank will be subject to a \$50.00 handling fee. In the event of two (2) consecutive refused checks, payment will be required by Certified Check or Money Order for a period of eighteen (18) months.
7. Any membership which has outstanding debts (including bad checks) to the EVUSA, any EVUSA official or the management of any EVUSA Recognized Competition or event will be notified in writing that they have twenty-one (21) days to clear all debts.
8. A membership will be declared "not in good standing" if the club or member fails to clear all debts within the allotted time or a club fails to submit the required Safety Report.
9. Memberships declared not in good standing will be notified in writing that they have been removed from the list of Registered Clubs or Members, as appropriate. In order to be reinstated as a Registered Club or Member in good standing all delinquencies must be cleared and a reinstatement fee of \$50.00 is required.
10. For an Individual Member to transfer membership from one club to another during a year in which dues are paid, a \$10.00 Membership Transfer Fee is required, accompanied by a completed official EVUSA Change Club Membership Form for each vaulter. Fee and form must be received by the National Office Manager or online before the transfer is valid.
11. Any individual who transfers Club membership after the close of entries of any EVUSA Recognized Competition in which he is already entered may not vault in any team event for his new club at that particular Recognized Competition(s).

### B. EVUSA Membership Assessments and Benefits

1. Club Memberships - Regular Clubs in good standing:
  - a. Regular Clubs must complete Club Registration each year. Regular Clubs shall pay an annual registration fee of \$65.00, if registration and payment is received or postmarked before January 1st. The registration fee for clubs registering on January 1st or later shall be \$75.00. Registrations will be returned if any information or fees are incorrect. Any number of individual vaulters may register with a club. Individual club members shall pay the appropriate dues as defined by their membership category. An Individual Member who vaults with a Club must be listed as a vaulter with that Club on his current membership form.

- i. May compete in EVUSA Recognized competitions as a Club.
  - ii. Receive one subscription to Equestrian Vaulting Magazine.
  - iii. Receive one printed copy of the EVUSA Rule Book.
  - iv. Receive access to the online EVUSA Rule Book and EVUSA Membership Directory. May receive, after request and payment of a fee, a printed copy of the EVUSA Directory which will be limited to ancillary directory information and will not include specific membership contact information.
  - v. Have access to the EVUSA members-only section of the website.
  - vi. Receive EVUSA Blasts.
  - vii. Receive members-only pricing on all EVUSA publications and merchandise.
- b. Recreational Clubs must complete a Club Registration Form each year. Forms are EVUSAilable from the National Office Manager. Vaulters, coaches and Lungers need not be EVUSA members. Affiliate Clubs shall pay annual dues of \$25.00.
- i. Receive one subscription of Equestrian Vaulting Magazine.
  - ii. May take the Novice Pin exam upon payment of a Non-Member fee. Individual Members of a Recreational Club who are regular Individual Members may compete at EVUSA Recognized competitions and represent their Recreational Club.
  - iii. Recreational Club Members may earn the Horsemanship Badge upon payment of a Non-Member fee.
  - iv. Have access to the EVUSA members-only section of the website, including the on-line EVUSA Rule Book and EVUSA Membership Directory.
  - v. Receive EVUSA Blasts.
  - vi. Receive members-only pricing on all EVUSA publications and merchandise.
  - vii. A Recreational Club Membership may be changed to a Regular Club Membership at any time by paying the difference between the Recreational Club Membership fee and the Regular Club fee.
2. Individual Memberships:
- a. Must register via mail (using the official EVUSA Membership Form) or online. All required information and proper fees must be received for the membership to be valid.
  - b. May register as a member of a current Registered Club, or as Independent (having no Registered Club affiliation).
  - c. Fees for Individual Membership
    - i. Fees for annual Individual Memberships vary according to the age of the member on January 1 of the membership year.
    - ii. Lifetime Individual Membership may be purchased for a one-time fee, and confers the applicable age-associated benefits of Individual Membership upon the Life Member.
    - iii. Family Membership allows an annual registration of a group of Individual Members, as defined in Article I, Section 5, for a single annual fee.
    - iv. Current Fees:
      - Individual, 18 years and older (“Adult member”): \$65 annually
      - Individual, not yet 18 years (“Youth member”): \$65 annually
      - Individual, not yet 7 years (“Tiny Tot member”): \$25 annually
      - Life Membership: \$750
      - Family Membership: \$125 annually
  - d. Benefits of Individual Membership
    - i. Individual membership benefits vary according to the age of the member on January 1 of the membership year, as indicated below.
    - ii. Individual Members in good standing shall be eligible to:
      - a. Compete in EVUSA Recognized competitions.
      - b. Take EVUSA Medal Tests.
      - c. Receive a subscription to Equestrian Vaulting Magazine.
      - d. Receive access to the on-line EVUSA Rule Book.
        - i. Individual Members who are a judge, serve as an EVUSA Officer or member of the EVUSA Board of Directors shall receive one printed copy of the EVUSA Rule Book.
      - e. Receive access to the online EVUSA Membership Directory.
      - f. Access the EVUSA members-only section of the website.

- g. Receive EVUSA Blasts.
  - h. Receive members-only pricing on all EVUSA publications and merchandise.
  - i. Vote in all EVUSA elections. (Adults only)
  - j. Serve as a member of the EVUSA Board of Directors (Adults only)
  - k. May hold Office. Serve as an EVUSA Officer (Adults only)
- iii. Any Individual Member,
    - a. May receive, after request and payment of a fee, a printed copy of the EVUSA Rule Book
    - b. May receive, after request and payment of a fee, a printed copy of the EVUSA Directory which will be limited to ancillary directory information and will not include specific membership contact information.
3. The fee charged for each printed copy of the EVUSA Rule Book and/or limited EVUSA Directory will be established by the EVUSA National Office Manager in an amount not to exceed the cost of printing and mailing.

## **SECTION II - VICE-PRESIDENTS**

- A. **Vice Presidents** shall hold office during the ensuing two years, until their successor's term commences on January 1st of the year following the election. The Vice President Membership, Vice President Development and Vice President Fundraising shall be elected in even numbered years; the Vice President Competitions and Vice President Education shall be elected in odd numbered years.

## **SECTION III - COMMITTEES — GENERAL RULES**

- A. Committee Chairmen shall manage their committee in accordance with the committee Charter that defines its duties, responsibilities, and scope of authority. Committee chairs shall prepare annual goals and priorities for approval by the Executive Board.
- B. Committee Chairmen shall submit an end-of-the-year report in December to the General Secretary for the Board of Directors.
- C. Expenditures for special projects, which have not been previously budgeted for nor approved by the Board, must be approved by the Executive Board.
- D. Only Committee Chairmen may submit requests for reimbursement. All requests must be itemized on the appropriate reimbursement form and accompanied by receipts.
- E. Nothing may be sent out as an EVUSA publication, survey, statistical poll, questionnaire, pamphlet, manual or book without prior approval of the Executive Board.

## **SECTION IV - NOMINATIONS AND ELECTIONS**

### **A. Nominations**

- 1. The General Secretary shall issue a call for self-nominations to the general membership by placing a notice through any membership- wide official communications of the Association, such as EVUSA Blasts, no later than July 31 of each year.
- 2. Nominations shall close August 31.
- 3. Nominee questionnaires shall be returned to the General Secretary by September 20. Nominees who fail to return the acceptance notice/questionnaire shall not be included on the ballot.

### **B. Elections**

- 1. The default method shall be by electronic votes submitted through an on-line election using a web interface.

2. The National Office Manager shall send a notice containing voting instructions, registration code and commencement date of the election, to all Individual Members, no later than October 5, and the closing date for voting through an electronic ballot shall be on or before October 15. Notice shall be sent by e-mail to the e-mail address of record with the EVUSA National Office.
3. Ballots shall be counted on or before October 20. The results shall be reported to the General Secretary within 24 hours of counting.
4. The General Secretary shall announce the election results in written form to all Board Members, candidates and the Membership on or before October 31.

## **SECTION V - REGIONS**

- A. An Individual Member's Region shall be determined by the Region of the Club with which they are registered. An Individual Member who is registered as an Independent will be a member of the Region in which they reside.
- B. In order to apply to become an EVUSA Region, an area must have a minimum of three (3) Registered Clubs and nine (9) Individual Adult Members for a period of two (2) consecutive years.
- C. Region Application Forms are EVUSAilable through the Vice President Membership. Completed forms must be submitted to the Vice President Membership for approval by the Executive Board and the Board of Directors.
- D. Regions may be registered as subordinate organizations under the Associations 501 c 3 status with the Internal Revenue Service by completing the appropriate paperwork with the EVUSA National Office.
- E. Once regional status is approved, a Regional Supervisor shall be appointed for the new Region by the EVUSA President, with the approval of the Board of Directors.
- F. The appointed Regional Supervisor becomes a member of the Board of Directors.
- G. After one (1) year of existence as an EVUSA Region, and once there are fifteen (15) Individual Adult Members and three (3) Registered Clubs in the EVUSA Region, the position of Regional Supervisor becomes an elected office of two (2) years. This election shall take place at the next scheduled election of Regional Supervisors. This position is to be nominated and voted on by all eligible Individual Adult Members in the given Region.
- H. The newly elected Regional Supervisor then becomes a member of the Board of Directors in place of the previously appointed Regional Supervisor.
- I. The Regional Supervisor's responsibilities are to function as a liaison between the EVUSA and his Region, to interpret EVUSA standards, and to support area growth. He is required to report any changes in administrative structure of the Region to the Vice President Membership.
- J. The internal structure of each Region (administrative, financial, competitions, etc.) shall be determined by the particular needs of that Region in accordance with existing EVUSA standards.
- K. If an approved Region's EVUSA membership drops below three (3) Registered Clubs AND fifteen (15) Individual Adult Members for more than two (2) years, the Region loses its right to an elected Regional Supervisor, and the EVUSA President shall again appoint a Regional Supervisor.
- L. If an approved Region's EVUSA membership drops below three (3) Registered Clubs for more than two (2) years, the Clubs in that Region shall be returned to the General Club status.
- M. If an approved Region's EVUSA Individual Adult Membership level drops below nine (9) Individual Adult Members for more than two (2) years, the Region's Individual Members shall be returned to General Membership status.
- N. The EVUSA assumes no financial responsibility for Regions.
- O.

## **SECTION VI - MEETINGS**

- A. Any duly called meeting of the Board of Directors or the Executive Board, or a General Meeting of the Membership, regardless of format (including teleconferencing and other technology based business communications), and attended by the required quorum shall be an official meeting of the body. All actions taken shall be considered official actions and all requirements for meetings as further defined in this section shall be met.
- B. Open Meetings
  - 1. All Board of Director and Executive Board meetings shall be open. Open meetings are defined as the opportunity for non-Board or Executive Board members to attend and observe the meeting. Participation in the meeting is at the discretion of the President.
  - 2. Meeting dates, times, and locations of regularly scheduled meetings shall be published in EVUSA Blasts and on the EVUSA website at the earliest possible opportunity, but not later than 14 days in advance of the meeting. For telephone conference calls and/or electronic meetings, the location information will be replaced by the means in which non-board or Executive Board members may call or sign-in as an attendee.
  - 3. The Board of Directors and Executive Board may hold emergency meetings without the 14 day notice provided that:
    - a) A majority of the Board or Executive Board members certify by majority vote that the meeting was an emergency.
    - b) Information regarding the date, time, and location is posted on the EVUSA website at the earliest possible time before the meeting takes place.
    - c) A summary of the meeting is posted on the EVUSA website within one week of the meeting.
- C. The Board of Directors and Executive Board may hold closed sessions for the purpose of discussing legal issues, contract negotiations, Board Member and Committee Member performance matters. The Executive Board shall conduct contract negotiations for the National Office Manager in closed session. The Board of Directors and Executive Board shall confirm that only matters permitted to be discussed in Closed Session were discussed immediately upon return to open session.
- D. A summary of each Board of Director and Executive Board meetings shall be posted on the EVUSA website within 14 days of the meeting; draft minutes of each meeting with a disclaimer that the minutes are draft minutes, subject to amendment and approval at the next Board of Director or Executive Board meeting, will be posted on the EVUSA website with 30 days of each meeting. Upon approval, the final, approved minutes of all meetings shall be posted on the EVUSA website to replace draft minutes.

## **SECTION VII - NATIONAL CHAMPIONSHIPS**

- A. The National Championships shall be held at a time and location approved by the Board of Directors.
- B. Vaulting Class lists at the National Championships shall be approved by the Technical Committee.
- C. Judges for the National Championships shall be appointed and scheduled by the Technical Committee.
- D. It is the responsibility of the Vice President Competitions to guarantee that all competing Club, Vaulters, Coach and Lunger registrations are current and to notify any of the above of any discrepancy prior to the start of the EVUSA National Championships.

## **SECTION VIII - RECOGNIZED COMPETITIONS**

### **A. Recognition**

There are two (2) categories of EVUSA Recognized Competitions, as follows:



**Level I - Open.** Any and all events, including team, individual, Pas de Deux and barrel are allowed.

**Level II - Limited.** Any and all individual events are allowed. Team Compulsories are allowed. No Team Freestyle and no Pas de Deux on the horse are allowed. All barrel classes are allowed.

1. Application to hold a Recognized Competition must be received by the National Office Manager, using the Application For EVUSA Recognized Competition form, and emailed, faxed or postmarked at least forty-five (45) days before the date of the Competition. Alternately, application may be submitted via online system provided by the EVUSA, at least forty-five (45) days before the date of the Competition. If the application is not submitted by the deadline, the Executive Board may authorize the National Office Manager to accept the late application with a late fee of \$250.00 in addition to the application fee. No applications will be accepted fewer than thirty (30) days before the date of the Competition.
2. Application must be signed by the Competition Manager (who must be an active member of the EVUSA in good standing). By signing the application form, the manager confirms that he or the sponsoring organization is financially responsible for the competition, ensuring that the competition is conducted in accordance with all EVUSA rules, regulations, and procedures, and will hold the EVUSA harmless in all respects.
3. Application must contain the following:
  - a. Date
  - b. Place
  - c. Events, divisions and classes offered
  - d. Name and address of secretary or manager
  - e. Entry closing date
  - f. Description of facilities, including dimensions of arena and height, if indoor or covered
  - g. Judge(s)
4. Payment by check or credit card of \$40.00 must accompany the application. The payment will be refunded if the date is not available or the Competition cannot be recognized.
5. Recognition may be granted to any Competition offering at least one (1) Recognized National Event. (See EVUSA Rules, Article 102.3 and 4) However, all Recognized National Event classes, if offered, must be run according to current EVUSA Rules.
6. The National Office Manager will notify both the show secretary and the EVUSA Competition Secretary, in writing of approval for recognition. The EVUSA Competition Secretary will provide any necessary paperwork for Recognized Competitions to the show secretary identified on the Application for Recognition.
7. No more than one (1) Recognized Competition may be held on the same day within a three hundred (300) mile radius. Preference for dates will be given to the team whose application is received first. The competition with priority may agree to allow another competition within three hundred (300) miles.
8. A copy of the prize list of a Recognized Competition must be sent to the EVUSA Competition Secretary, the Technical Committee Chairman, the Judges, and all Registered Clubs in the region at least thirty (30) days prior to the competition, otherwise, recognition will be rescinded. Emailed notification of Prize List availability meets the prize list distribution requirement.
9. The prize list must contain the following:
  - a. Date, time and place of competition
  - b. Fees
  - c. Entry closing date and post entry policy
  - d. Judge(s)
  - e. Availability of stabling, housing and eating facilities
  - f. Events, divisions and classes offered
  - g. Names of classes or divisions which are recognized
  - h. Description of footing and dimensions of arena, including height of ceiling, if applicable
  - i. Time and place of draw
  - j. Acceptable format(s) for competitors' music, with instructions and deadlines for submitting music.

- k. All unrecognized classes must have specific deductions listed
10. Judges must be chosen from the current list of Recognized Judges in good standing. Foreign Judges may be granted a guest card by the Technical Committee to judge a specific competition.
11. An EVUSA Judging Contract form and current list of active Judges are available from the National Office Manager or on the EVUSA website.
- 12.

## **B. Insurance**

1. A recognized competition must obtain insurance naming the EVUSA as additional insured for each day of the competition, including set-up and take-down days, with minimum limits of \$2,000,000 third party general liability insurance and \$50,000 on equipment and property.
2. A certificate of insurance for each competition must be received by the National Office at least fourteen (14) calendar days prior to the competition, by mail with proof of delivery or submitted electronically via upload to the EVUSA's online competition management system, via e-mail or via fax. Competitions faxing their certificate of insurance must retain a copy of the fax confirmation. Failure to provide certificate of insurance fourteen (14) days prior to the event will result in forced placement of insurance with a provider of EVUSA's choice for a fee which shall cover the cost of the insurance for each competition day, plus a \$100 administrative fee. This fee will be assessed to the Competition Manager listed on the recognition application form, and must be paid within ten (10) days of the close of the recognized competition or the manager will not be in good standing with the EVUSA and an additional \$50 late fee will be assessed.

## **C. Entries**

1. For Recognized Competitions, entries (clubs, coaches, lungers and vaulters) must be Registered Clubs and Individuals of the EVUSA in good standing, or must pay a non-member fee. This rule does not apply to foreign teams or individuals
2. Non-Member Fee - Individuals, including vaulters, coaches and lungers, who are not current EVUSA members as of the start of the first day of competition must pay a non-member fee in order to participate in an EVUSA Recognized Competition. A non-member fee allows the individual to participate in said EVUSA Recognized Competition and to receive ribbons and placings. However, as the individual was not an EVUSA member for the competition, their scores may not be used for any Year-End awards.
3. Post entries may be accepted for EVUSA Recognized Competitions. Post entry is defined as an entry received by Competition Management postmarked (or otherwise delivered) after the close of entries. When a Recognized Competition does not accept post entries it must be stated in the prize list and no exceptions can be made. When a Recognized Competition does accept post entries it must be stated in the prize list and post entries can only be accepted prior to the final date stated in the prize list for post entry submission. Allowing additions, deletions, and changes of classes by competitors already entered in a Recognized Competition is left strictly up to the Competition Management and must be published in their prize list.
4. If only one (1) Registered B or C Team enters a division, that team has the option to compete at the next higher (not lower) division. The team's coach must initial the division change on the score sheet. Scores can count toward Annual Awards in the division originally entered. Management must indicate on the score sheet in which division the score is to count.
5. For all Recognized Competitions, an \$8.00 surcharge per vaulter, including foreign vaulters, will be assessed by and paid to the EVUSA.
  - f.
6. Following the close of a Recognized Competition:
  - a. Management must send the Competition Secretary:
    - Any Non-Member Forms submitted. (see Section VIII.C.2)

- All competition and Non-Member fees due to the EVUSA, payable by credit card to check payable to EVUSA, including vaulter surcharge fees.
  - A copy of the competition results, vaulter names, EVUSA numbers, scores and placings for all classes;
    - This packet, including all documents, must be postmarked or otherwise delivered, within ten (10) days of the close of a Recognized Competition, or a late charge of \$50 will be assessed. All documents may be provided as physical copies or in digital form. Delivery of this packet may be made electronically via email, uploading files, or as otherwise specified by the Competition Secretary.
- b. Management must retain in its own records for one (1) year from the final day of the Recognized Competition:
    - An alphabetized list of all competing vaulters, coaches and lungers, showing EVUSA Membership numbers and club affiliation, and clearly indicating the names of the non-members and the total number of competing vaulters.
    - Original score sheets for all Recognized Classes, either hard copy of digitized/scanned copy.
    - A list of all horses, and their EVUSA number if they have one.
  - c. .
7. The EVUSA Competition Secretary will notify the Show Secretary (Management) within six (6) days of receipt of the above materials, of any errors and/or omissions regarding the submittals. Competition Management shall have seven (7) days from the date of the notification to correct the errors. In the event the proper paperwork and fees are not sent to the EVUSA Competition Secretary as of that date, a \$100 fine shall be assessed to the Show Secretary (Management).

#### **D. Facilities**

1. Footing in the vaulting arena should be level, soft and springy — neither slick nor too deep. Shavings, sand or a mixture of shavings and sand is suitable.
2. The arena should be groomed and maintained during the competition. The Judge(s) may request that the ring be groomed at any time.
3. Regulation Barrel must meet height and handle specifications as indicated (See “Barrel Specifications” at the back of this book).
4. Footing in the barrel arena must be suitable for vaulting. The top of the barrel must measure 48” from the ground. If extra footing is placed around the barrel, the top of the barrel must still measure 48” from the top of the extra footing.

#### **E. Scoring**

1. The Score Sheet
  - a. EVUSA Score Sheets or their electronic equivalents must be used.
  - b. Score Sheet masters will be provided by the Competition Secretary if requested by Competition Management.
  - c. Score Sheets must contain the following information:
    - 1) Name of team or individual vaulter(s)
    - 2) Division entered
    - 3) Name of each team vaulter
    - 4) Final score
    - 5) Name of lunger and horse
    - 6) Signature of Judge
    - 7) Name and date of competition

#### **F. Format**

1. Recognized Competitions must be held according to EVUSA Rules for Vaulting. All Recognized National Event classes, if offered, must be held according to EVUSA Rules for Vaulting. Any and all unrecognized

classes if offered during recognized competition hours, must follow EVUSA Rules for vaulting, Article 103.1, Article 104, Article 105, Article 106, Article 109, Article 110.9 (for any barrel classes), and Article 111.9.

2. Order of go. Note: sections a, b, and c were suspended by the EVUSA Board of Directors as of 9/19/2020 to facilitate COVID-related adjustments to competitions. They will remain suspended until further Board action.
  - a. ~~In Team Competition, order of go must reflect a complete level. All Trot teams go together; all C teams go together; all B teams go together; all A teams go together.~~
  - b. ~~In individual classes, order of go must reflect a complete level. All Trot go together; all Copper go together; all Bronze go together; all Silver go together; all Gold go together, all Individual 3\* go together.~~
  - c. ~~In 2-Phase Team, order of go for each phase must be different and shall reflect a complete level in Team Event as stated above.~~
  - d. In the event the same horse goes twice in a section, the times for the horse to go may be scheduled as far apart as possible.
3. A veterinarian must be on call for all Recognized Competitions. Phone number must be conspicuously posted in stable area and show office and readily available by management.
4. An emergency medical service must be on call for all Recognized Competitions. Phone number and directions to the nearest hospital must be conspicuously posted in stable area and show office and readily available by management.
5. A score board must be conspicuously placed, and scores kept posted as currently as possible. Score sheets may be examined only by the office management and Judges until they are officially posted.
6. Score sheets must be made available to the coach at close of competition.
7. Protocol
  - a. All lungers and vaulters must be properly turned out.
  - b. Horse's mane must be braided or roached.
8. If an infraction of the rules is discovered within fifteen (15) days of the close of the competition, it shall result in immediate notification by Show Management to the coach. Appropriate action shall be taken by the Show Management in consultation with the President of the Ground Jury. The Club or Individual involved will have fifteen (15) days from the date of the notification to appeal the action, and the EVUSA will have fifteen (15) days from the date of receipt of the appeal to respond to the appeal.

## **SECTION IX - MEDAL EXAMINATIONS**

(See also EVUSA Rules for Vaulting, Chapter IV) Medal tests are available for the following individual levels: Trot, Copper, Bronze, Silver and Gold. Novice pins are available at walk, trot and canter. (There is no medal for Individual 3\*.)

### **A. Fees**

1. Fees for Trot, Copper, Bronze, Silver and Gold are \$25.00 per Vaulters per Exam. Fees for Novice are \$15.00 per Vaulters per Exam.
2. If Application is received less than thirty (30) days prior to date requested for Exam, an additional \$10.00 late fee will be applied to the basic Medal exam fee for each Exam and must be included in the check or money order. The late fee shall be waived for retakes within forty-eight (48) hours.
3. All fees must be in U.S. funds.
4. An application received less than twenty (20) days prior to the date requested for the Exam may be impossible to process.

5. All expenses of the Examiner (travel, food, lodging, etc.) are the responsibility of the management of the Exam. In addition, a fee of \$50.00 is a standard minimum for an Examiner. Expenses should be discussed before the Exam.
6. An EVUSA Judging Contract is available on the EVUSA website or from the National Office Manager.
7. Individual fees may be transferred to another vaulter in the same Club for an Exam on the same day only. However, individual fees will not be refunded or credited to a later exam.
8. In the event an entire Exam is canceled, fees will be refunded.

## **B. Procedures**

1. Application Forms
  - a. Application Forms must be submitted to the Medal Test Secretary. Application Forms are available for download from the EVUSA Website for Registered Clubs, Individual Members or Affiliate Groups in good standing.
  - b. Forms must be completed correctly, typed or clearly printed.
  - c. All incomplete or incorrect forms will be returned. Late fees will apply where applicable.
    - 1) All applications must be accompanied by a check or money order for the full amount, including any late fees, made payable to the EVUSA.
    - 2) All vaulters on the application must be current EVUSA members at the time the application is sent to the Medal Test Secretary.
    - 3) A list of all bronze, silver and gold freestyle exercises must accompany the application for approval by the Medal Test Secretary.
  - d. Applications not accompanied by a check or accompanied by a check incorrectly made out will be returned.
  - e. Applications not accompanied by the list of bronze, silver and/ or gold freestyle exercises will be returned. Late fees will apply where applicable.
  - f. Applications must be on the official form. Applications by telephone, fax or personal note will not be accepted.
2. The Medal Test Secretary will do the following:
  - a. Send score sheets, medals and ribbons to the Registered Club, Individual Member or Affiliate Group requesting them.
  - b. Send a list of paid candidates to the Club, Individual Member or Affiliate Group to be given to the Examiner prior to the start of the Exam.
  - c. Send list of approved Freestyle exercises for bronze, silver and/ or gold exams to be given to the Examiner prior to the start of the Exam.

**Note:** No medal test materials will be sent if the application and enclosures are incomplete in any way. (See Section IX.B.c above)

3. Any substitutions or additions to the official list of candidates must be given to the Examiner prior to the start of the Exam. Proof of EVUSA membership must be shown and all fees, including late charges, must be paid to the Examiner for any additional vaulters before the start of the exam.
4. No vaulter will be tested who has not paid all his fees.
5. The completed and signed score sheets and any additional fees must be returned by the Examiner to the Medal Test Secretary within one (1) week after the Exam.
6. All unused ribbons and medals must be returned by the Club's manager or coach to the Medal Test Secretary within two (2) weeks after the Exam.
7. A \$100.00 fine will be imposed if unused ribbons and medals are not returned within the allotted time.

8. A \$50.00 fine will be assessed to the judge and/or club for improper procedure reported by the Medal Test Secretary to the Executive Board.

### **C. Examiners**

1. See EVUSA Rules for Vaulting, Chapter V - JUDGES.
2. Clubs should choose their own Examiner. Contact the Medal Test Secretary if help is needed in finding an Examiner.

### **D. General Information**

1. See EVUSA Rules for Vaulting, Chapter IV - MEDALS.
2. The score sheets must be filled out completely and indicate clearly how, and in what order, the Freestyle exercises are to be performed.
3. Medals to the left shall have different colored ribbons designating Commended or With Honors.
4. Medals to the right shall have a bar attached to the ribbon designating Commended or With Honors. Said bars shall be sent to the team after the results are submitted to the Medal Test Secretary.

### **E. Protocol**

1. Management should provide a suitable place for each Examiner to sit, protected from sun, wind, dust, etc., including chairs for each Examiner and Clerk, table, score sheets, sharp pencils with erasers, a bell, and a calculator. The Clerk or scorekeeper should tally the results as soon as the Examiner releases them. Results should be announced as soon as possible with the Examiner's approval.
2. Horses, lungers and vaulters should be smartly turned out.
3. Horse's mane must be braided or roached.
4. The vaulting arena must be groomed.
5. A team must salute the Examiner upon entering and exiting the arena.
6. The Examiner may give a critique at the end of the Exam.

## **SECTION X - JUDGES PROGRAM**

(See also EVUSA Rules for Vaulting, Chapter V - JUDGES)

### **A. Fees**

1. A \$50.00 fee is required on promotion to Registered Judge "R".
2. A \$50.00 fee is required on promotion to Recorded Judge "r".

### **B. Apprentice Program Application**

1. Application forms for the program are available upon request from the Chairman of the Technical Committee.
2. Applicants must complete the application form and return it electronically to the Chairman of the Technical Committee along with the non-refundable application fee.

### **C. Procedure**

1. Apprentice applications will be accepted at any time during the calendar year.

2. Applications received must be accompanied by a non-refundable \$100.00 application fee. The applicant will have until December 31 of the year the application is received to fulfill all requirements for entry into the program. (see Article 706 Apprentice Program).
3. Any number of applicants may be accepted in any one (1) year.
4. The screening and selection panel appointed by the Technical Committee will review applications and questionnaires after December 31.
5. Applicants will be notified of the decision of the screening panel by March 1. Applicants must then pass a written exam before acceptance into the program. Applicants who are not accepted into the program may reapply the following year.

## **SECTION XI - PROTESTS & GRIEVANCES**

(See EVUSA Rules for Vaulting, Chapter VI, Protests and Grievances for further information)

### **A. Fees**

1. Protests must be submitted with a filing fee of \$50.00
2. Grievances must be submitted with a filing fee of \$50.00

# BARREL SPECIFICATIONS

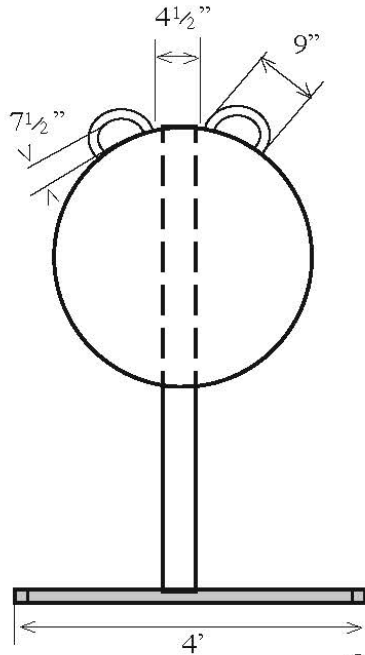

*Dimensions here are given without padding.*

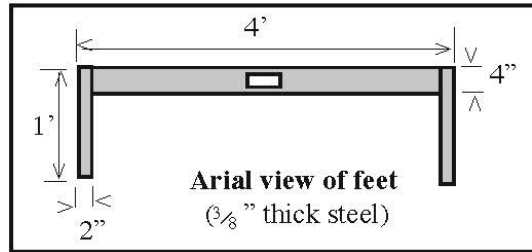

Vaulting barrels must be situated in an area clear of impediments (overhead and to the sides). The ground must be level, soft and springy.

Legs must not project beyond sides of barrel.

The feet must be covered and it is best to secure them to the ground.

Barrel handles may be configured within the boundaries of any legal vaulting surcingle as defined in the FEI Vaulting Rules Article 719.2.3

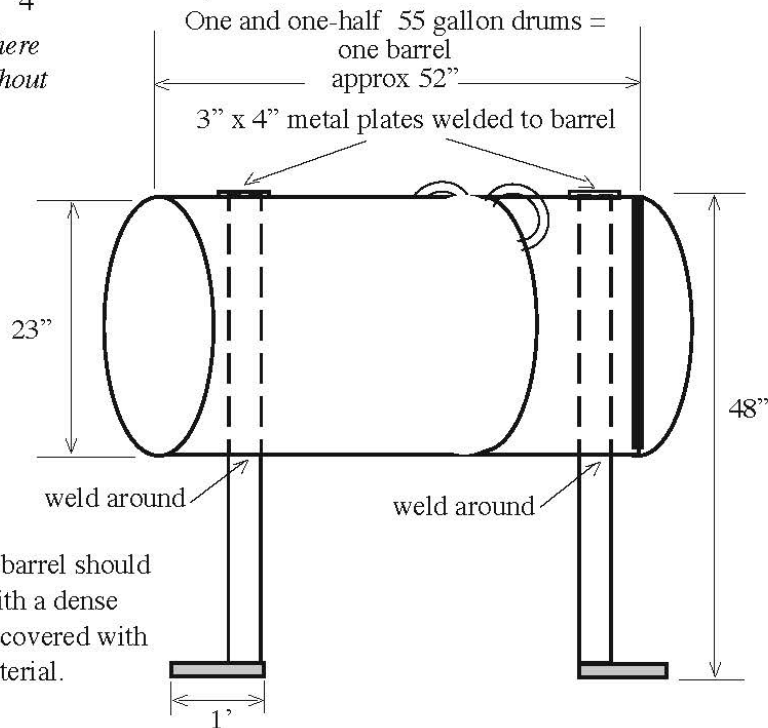

The finished barrel should be padded with a dense padding and covered with a durable material.

*For questions about any barrel to be used for AVA recognized competition, please contact the Chair of the Technical Committee.*