

Equestrian Vaulting USA

2026 RULE BOOK

**Vaulting
Rules**



Equestrian Vaulting USA is a member of the
United States Equestrian Federation.

THE MOST CURRENT ONLINE
VERSION OF THIS RULE BOOK SUPERSEDES
ALL PREVIOUS EDITIONS

(Rule Book updated 1/20/2026)

Equestrian Vaulting USA
1443 E. Washington Blvd, # 289
Pasadena, CA 91104
Phone: 323/654-0800, Fax: 323/654-4306
Email: info@equestrianvaulting.org

Visit www.equestrianvaulting.org for current rules, more
information and contacts.

Copyright© 2026 by the Equestrian Vaulting USA.
All rights reserved. Reproduction without permission is strictly prohibited.

EVUSA RULES FOR VAULTING	4
CHAPTER I. GENERAL	4
CHAPTER II. COMPETITION	4
CHAPTER III. HORSES	8
CHAPTER IV. RECOGNIZED NATIONAL EVENTS	11
INDIVIDUAL EVENTS	12
PAS DE DEUX EVENTS	17
TWO-PHASE SQUAD EVENTS	19
SQUAD EVENTS	20
CHAPTER V. SCORING	24
CHAPTER VI. MEDALS	33
CHAPTER VII. JUDGES	35
CHAPTER VIII. PROTESTS AND GRIEVANCES	37
CHAPTER IX. AMENDMENTS TO THE RULE BOOK	38
GUIDELINES	39
CHAPTER X. GENERAL, ELIGIBILITY AND AWARDS	39
APPENDIX A – BARREL CLASSES	40
CHAPTER XI. INDIVIDUAL BARREL EVENTS	40
CHAPTER XII. PAS DE DEUX AND SQUAD BARREL EVENTS	40
APPENDIX B – PRELIMINARY 1* HORSE EVENTS	41
CHAPTER XIII. 1* PRELIMINARY INDIVIDUAL - HORSE	41
CHAPTER XIV. 1* PRELIMINARY PAS DE DEUX AND SQUAD - HORSE	41
APPENDIX C - D HORSE EVENTS	42
CHAPTER XV. D INDIVIDUAL – HORSE	42
CHAPTER XVI. D PAS DE DEUX AND SQUAD – HORSE	43
CHAPTER XVII. DESCRIPTION OF D COMPULSORIES	44
APPENDIX D – CONSIDERATION OF THE BARREL	48
APPENDIX E – GENERAL IMPRESSION	49
APPENDIX F – TROT AND WALK HORSE SCORE	50
CHAPTER XVIII Trot and Walk Horse Score	50

APPENDIX G

53

JUDGES DISTRIBUTION

53

BARREL SPECIFICATIONS

54

EVUSA RULES FOR VAULTING

Rules for Vaulting are the rules for the performance of the sport of vaulting. Rules for Vaulting are developed by the Technical Committee and presented to the Board of Directors for consideration and, upon concurrence, adoption.

CHAPTER I. GENERAL

Article 101. Introduction.

1. **Vaulting:** The art of gymnastics/dance on the moving horse. The competition is judged on the smooth and correct execution of the compulsory exercises, freestyle programs and technical tests by the vaulters in sympathy and harmony with the horse working on the lunge line.
2. **Harmony with the Horse:** is achieved by performing every movement, compulsory or freestyle, in unity with the horse. A horse's movement produces significant power and inertia, and harmony is achieved when a vaulter balances their strength and suppleness to synchronize with that movement. The objective is to create a cohesive unit consisting of the Lunger, Horse and Vaulter(s) working as one, with vaulter(s) moving in accord with and causing no adverse effect on the horse. The horse should be a willing partner totally accepting of the vaulter(s) with uninterrupted balance and free flowing movement.

CHAPTER II. COMPETITION

Article 201. Competition Recognition.

1. All EVUSA Recognized Competitions must have completed procedures for recognition as per Standing Rules. (See Standing Rules, Section VIII – Recognized Competitions).
2. All EVUSA Recognized Competitions must be held according to current EVUSA rules. If a competition is USEF and EVUSA recognized, USEF rules shall take precedence.
3. Recognition may be granted to any competition offering at least one (1) EVUSA Recognized National Event. All Recognized National Events must be held according to current EVUSA rules.
4. Recognized National Events:
 - a) Individual: 3*, 2* Young Vaulter/Gold, 2* Silver, 1* Bronze, 1* Copper or 1* Trot
 - b) Pas de Deux: 3* Canter, 2* Canter, 1* Canter and 1* Trot
 - c) Squad Two-Phase: 2* Canter, 1* Canter and 1* Trot
 - d) Squad: 3* A, 2* B, 1* C and 1* Trot

Article 202. Eligibility.

1. All clubs, vaulters, coaches and lungers must be registered members of the EVUSA in good standing in order to compete in an EVUSA Recognized Competition. For purposes of competition, a member in good standing is one:
 - a) Who has paid their current EVUSA dues
 - b) Who has paid the club registration fee
 - c) Who meets eligibility requirements per EVUSA By-laws and Standing Rules, including but not limited to requirements for SafeSport training and minor athlete safeguarding policies and practices. Any member who appears on the U.S. Center for SafeSport banned or suspended list, or whose membership is suspended or terminated by USEF or FEI may not participate.
 - d) Who has no outstanding debts to the EVUSA, judge or competition
2. At National Championships, foreign individual competitors are allowed to compete but are ineligible for National Championship titles.
 - a) All Foreign athletes who are 18 years of age or older participating in any EVUSA Recognized Competition must be SafeSport trained and follow all SafeSport rules and recommendations and to follow minor athlete safeguarding policies and practices including but not limited to Minor Athlete Abuse and Prevention.
 - b) A foreign individual competitor may compete for scores and may be awarded ribbons and placings (See Standing Rules, Section VIII.C.1 and 2).
 - c) A Squad may have up to two (2) foreign vaulters as members and be eligible for awards provided that each of the foreign competitors has complied with United States Equestrian Federation (USEF) membership requirements. Foreign competitors and lungers who desire to compete in National

- Championships must have proof, in English, of membership in good standing from their National Federation or must be members in good standing of the EVUSA and the United States Equestrian Federation. These documents must be made available to Competition Management prior to the start of the first day of competition for any USEF competition.
- d) A Squad with more than two (2) foreign vaulters as members, whether or not they have met the above requirements, or a Squad with any number of foreign vaulters who have not met the above requirements may compete for scores only.

Article 203. Competitors and Classifications.

1. A vaulter may enter the same event only once at any competition.
2. There are no age restrictions for Recognized National Events.
3. A vaulter's classification for Recognized National Events is determined by the highest level at which they have competed at any EVUSA competition. This classification is determined as of the closing date of entries of the competition.
4. Vaulters who hold a canter medal may vault in a higher division than their medal level in individual competition in Recognized National Events.

Article 204. Substitution.

1. Recognized National Squad Event:
 - a) One (1) substitute is allowed. In order for a substitute to vault, they must enter the ring with the Squad as its seventh member at the start of Compulsories. The substitute must be a member of that club.
 - b) The substitute vaults in the seventh position.
 - c) A vaulter may not be entered as the substitute in more than one (1) division of Squad Canter Event.
 - d) Using a substitute other than is stated is illegal and results in elimination.
2. Squad 2-Phase Event:
 - a) One (1) substitute is allowed. In order for a substitute to vault, they must enter the ring with the Squad as its fifth member at the start of Compulsories. The substitute must be a member of that club.
 - b) The substitute vaults in the fifth position.
 - c) A vaulter may not be entered as the substitute in more than one (1) division of Squad Two-Phase Event.
 - d) Using a substitute other than is stated is illegal and results in elimination.
3. Individual Event, Pas de Deux Event: No substitution is allowed in Individual or Pas de Deux Events.
4. Lungers: Substitution is permitted between sections in all events.
5. Horses: Substitution is permitted between sections in all events.
6. Equipment: Substitution is permitted between sections in all events

Article 205. Facilities.

1. For Level I Recognized Competitions: The vaulting arena must be at least 22 meters (72.5 feet) in diameter with suitable footing. If the competition is held indoors or under cover, the ceiling height must be at least 5 meters (16.5 feet).
2. For Level II Recognized Competitions: The vaulting arena must be at least 20.5 meters (67.5 feet) in diameter with suitable footing. If the competition is held indoors or under cover, the ceiling height must be at least 4.7 meters (15.5 feet).
3. The diameter of the lungeing circle must be between 13 and 15 meters (42.5 to 50 feet). The center of the circle must be clearly marked.
4. If the entire vaulting arena is not suitable vaulting surface, then the suitable vaulting surface must extend from 2 meters (6.6 feet) from the center point of the circle to at least 11 meters (36 ft) from the center point of the circle for Level I Recognized Competitions and to at least 10.28 meters (33.75 feet) from the center point of the circle for Level II Recognized Competitions.
5. The judge's booth(s) should be at least 12 meters (40 feet) from the center of the vaulting arena elevated at least .5 meter (1.5 feet) above the competition arena. Steps and protection from the elements must be provided.
6. Spectators must be located at a reasonable distance from the vaulting circle and judge's booth(s).
7. A suitable warm-up arena must be provided. An additional area for horse warm up must also be provided.
8. A ring steward must be present at each competition arena at all times during the competition.

9. For Squad Two-Phase Event, an EVUSA regulation barrel is required. The handles are placed to the judge's left. The footing in the barrel arena must be suitable for vaulting. (See Standing Rules, Section VIII.D.4).
10. A countdown clock and one (1) stopwatch must be provided at the Judge at A stand in each arena, or an official timer must be appointed, who shall sit next to the Judge at A in each arena. If an official timer is needed, two (2) stop watches must be provided; one (1) to be used to time the performance and the other for timing entry, falls, time-outs, etc.
11. A bell must be provided for the Judge at A.

Article 206. Format.

1. Competitors are to salute the Judge at A upon entering and before exiting the arena, unless excused by the judge (see article 504.3.f-g).
2. Before beginning the performance, the horse must be trotted on the circle until the judge rings the bell to proceed. At this time, one (1) minute is allowed for horse warm-up, if requested. Vaulters are not allowed to approach or mount the horse during this warm-up. Vaulters may begin immediately (if no warm-up was requested) or wait for the bell to indicate the end of the warm-up at which time vaulter MUST begin the performance. (see article 504.3.h)
3. All competition at the canter must be performed on the correct lead, not in counter canter.
4. **Competition is at the canter to the left or to the right for all events, unless otherwise specified. Each time a horse enters the arena they must perform all goes to the same direction.**
5. Order of go for all events must be determined by draw, by club, for each section of the event. Management may draw for all entrants. For Individuals the coach must specify order of vaulters.
 - a) Time of draw must be at least one (1) hour before the start of the competition.
 - b) Time and place of draw shall be announced in the prize list.
5. Music is recommended during all performances. It is preferred that music be continuous for all competitors on the same horse during Individual compulsories.
 - a) Music to be provided by the competitor, according to the equipment available.
 - b) Management must state in the prize list which system(s) will be available.

Article 207. Timing.

1. The time allowed for each event begins the moment the first vaulter touches the surcingle, the pad or the horse and ends with the time limit (the bell). Only exercises (static or dynamic, including dismounts) already in progress when the bell rings will be included in the evaluation for degree of difficulty, performance and Artistic. All exercises and dismounts starting after the bell will be considered in the performance score (deductions only), but not in the Degree of Difficulty and Artistic scores. For timing requirements of specific events, please refer to the chapter for that event.
2. A bell is used by the Judge at A to signal the competitors on the following occasions:
 - a) To give the signal to enter the arena
 - within one (1) minute after the bell, the vaulter(s) must salute the Judge at A.
 - b) To give the signal at the end of the trot requirement to start the Compulsory test, the Freestyle test, and the Technical Program
 - within thirty (30) seconds after the bell, the vaulter(s) MUST start the performance.
 - c) To signal the end of time
 - d) To signal the competitor(s) to stop in case of unforeseen circumstances
 - the clock will be stopped and judging will cease.
 - e) To signal that time is stopped after a fall when the vaulter has lost contact with the horse or surcingle in Individual Freestyle or Individual Technical Program.
 - f) To signal that time is stopped after a fall where the vaulter(s) is unable to continue immediately or return to the line in Squad Freestyle.
 - g) To signal the competitor(s) to continue after an interruption.
 - The clock is started and judging begins when the vaulter touches the grip.
 - The test must be continued within thirty (30) seconds after the signal to resume.
 - h) To signal time-out in all events
3. Time-out in all events:
 - a) In case of an injury or illness, the event and the clock will be stopped. The judge will indicate when the event and the clock will resume.

- b) In the event of a horse casting a shoe or the breakage of equipment, the clock will be stopped for a maximum of seven (7) minutes.
 - c) The lunger may request one (1) time-out per performance to adjust equipment. The clock will be stopped for a maximum of one (1) minute. At the lunger's request, the judge may give permission for outside assistance. The lunger may also adjust the equipment, if necessary, in between vaulters during individual freestyle, while the judge is scoring the previous freestyle.
 - d) In the event that the freestyle music is not correct or malfunctions, the lunger may request a time out. The clock will be stopped for a maximum of two (2) minutes. No one in the arena may leave to assist. Assistance can be requested and someone outside the competition arena may go to the music stand. If the malfunction occurs during the performance, and the clock is stopped, the vaulter(s) begin where they left off.
 - e) In the case of unforeseen circumstances, the bell will be sounded to indicate to the vaulter(s) to stop. The clock will be stopped and judging will cease. A bell will sound to indicate that the vaulter(s) is/are to recommence the performance. The clock will resume when the vaulter(s) retake the grips.
4. See EVUSA Rules Chapter V. Scoring for penalties and deductions.

Article 208. Unauthorized Assistance. (See also Article 504.3.j)

- 1. No one other than the lunger may give any directive to the horse.
- 2. No one is permitted to approach the horse without the intention of mounting except the booster in any/all recognized 1* Trot classes.
- 3. In all EVUSA Recognized classes, except any/all 1* Trot, no boosting of vaulters is permitted.
- 4. In Recognized Squad Events, except 1* Trot Squad where one (1) additional person may enter as a booster, no one other than a lunger, a Squad of six (6) members and one (1) substitute may be in the arena for Squad Compulsories. The substitute as declared by the Squad coach may not enter the arena for Squad Freestyle.
- 5. In Recognized Pas de Deux Event, except 1* Trot Pas de Deux where one (1) additional person may enter as a booster, no one other than a lunger and members of the Pas de Deux pair who are scheduled to compete at that specific time may be in the circle.
- 6. In Individual Event, except 1* Trot where one (1) additional person may enter as a booster, no one other than a lunger and individual(s) who are scheduled to compete at that specific time may be in the arena.
 - a) For Compulsories and Freestyle only one (1) vaulter may be in the competition circle at a time, if the booster is another vaulter competing at the same time, they must leave the circle immediately after the boost is given.
 - b) Other competitors shall line-up outside the competition circle.
 - c) For Compulsories the next competitor may enter the competition circle when the previous vaulter begins the vault-off.
 - d) For Freestyle the next vaulter enters the competition circle when the previous vaulter has dismounted, they may not begin their performance until the Judge at A rings the bell.
 - e) An earlier entry entails elimination of the incoming vaulter.
- 7. See EVUSA Rules Chapter V. Scoring for penalties and deductions.

Article 209. Vaulter Identification and Attire.

- 1. In recognized national Squad events, each Squad member must wear a number from 1 through 7 and must vault in that order for the compulsory section. Numbers must be easily visible to the judge(s).
- 2. Individual vaulters must wear a number which has been assigned to them by the EVUSA National Office. Number may be worn on the right arm or right leg and must be easily visible to the judge(s). Suggested dimensions and contrasts: number band 2"-2.5" (5-6.5 cm) and numbers 1.5"-2.0" (4.-5 cm) high; dark numbers on light band or light numbers on dark band.
- 3. The dress for vaulters must be suitable for equestrian sport. It must not hinder the movement of the vaulter or the safe interaction between vaulters during the performance. The dress must in no way compromise the safety of either vaulter or horse.
 - a) The dress must not conceal the form and line of the vaulter's body during the performance in order not to hinder the judging of the exercises.
 - b) The dress must be form-fitting and all parts of the uniform must remain attached to the vaulter's body at all times (i.e. vests, belts, decorative designs, etc must be sewn directly to the uniform).
- 4. Decorative accessories (not limited to but including belts, masks, jewelry) and props (not limited to but including hats, capes, canes, gadgets) are strictly forbidden in the arena.

5. Soft-soled shoes are required.
6. Trousers must be secured to the foot and skirts may only be worn over tights or leggings.
7. The apparel of the lunger should be harmonious with that of the vaulter(s) and must be clean, neat and professional. Lungers may wear belts, hats and/or scarfs, but should restrict their use of decorative accessories and adhere to the suitability for equestrian sport.
8. The apparel of the booster should be appropriate for equestrian sport.

Article 210. Officials.

1. Judges:
 - a) At least one (1) EVUSA Recognized Judge is required at each Recognized National Event, except at National Championships where at least two (2) EVUSA Recognized Judges are required for each Recognized National Event.
 - b) For every EVUSA Recognized competition or class with two (2) or more judges, the distribution of responsibilities will be as outlined in Appendix E.
 - c) To receive a qualifying score for the National Championships, the competition must have been judged by at least two (2) EVUSA recognized judges.
2. Ground Jury:
 - a) The invited judge(s) comprise the Ground Jury and must be selected from the current roster of EVUSA Recognized Vaulting Judges.
 - b) The President of the Ground Jury must be appointed by the organizing committee from the officiating judges.
 - c) The judge sitting at A, whether President of the Ground Jury or not, is in charge of managing the arena and is the official time keeper.
3. Steward/Technical Delegate:
 - a) At National Championships, there must be a USEF licensed steward or technical delegate selected by the organizing committee.
 - b) At EVUSA Recognized Competitions where there is no technical delegate, the President of the Ground Jury acts as the technical delegate.

CHAPTER III. HORSES

Article 301. Horses.

1. Vaulting horses must be at least six (6) years old, of any breed or suitable size.
2. Stallions are prohibited.

Article 302. Welfare of the Horse

1. Welfare of the Horse while in the competition arena:
 - a) During any performance due to an unforeseen event or circumstance the Judge at A may request an additional trot circle to determine if a horse is uneven/unlevel and/or unable to continue due to fitness, distress or injury. The horse must trot until the best is run to signal the performance may resume.
 - b) Tripping - In the event a horse trips and touches the ground with the front knee(s) and/or nose, the horse may not continue for that go and is excused for the remainder of the class.
 - c) Falling - In the event a horse falls and the shoulder and/or hip touches the ground, the horse may not continue for that go and is excused for the rest of the competition.
 - d) Blood - In any event there is fresh blood or a wound is currently bleeding on a horse, the horse may not continue for that go and is excused for the remainder of the class.
 - e) While in the competition arena a horse may only be inside reins for the following length of time: 1 Squad, 2 Pas de Deux and 4 Individuals. If a horse is inside reins longer than the lengths listed, additional vaulters for that go will be disqualified.
 - f) **It is not mandatory to remove the side reins in the arena after all vaulters have performed. Side reins may be removed any time after the last vaulter dismounts.**
 - **While the horse is still on the circle**
 - **After they come into the center**
 - **After the salute is complete or**
 - **Immediately after exiting competition arena**

Article 303. Horse Use.

1. Canter: Horses may be used for a maximum of 18 units each day.
 - a) Squad Canter Event:
 - 1 Squad Compulsories = 6 units
 - 1 Squad Freestyle = 6 units
 - b) Individual Canter Event:
 - 1 Compulsories = 1 unit
 - 1 Freestyle = 1 unit
 - 1 Technical Test = 1 unit
 - c) Pas de Deux Events:
 - Freestyle = 2 units
 - 1* Compulsories = 2.0 units
 - d) Squad Two-Phase Event:
 - 1 Squad Compulsories = 4 units
2. **Walk and Trot:** Horses may be used for a maximum of 24 units each day.
 - a) Squad Trot Event:
 - 1 Squad Compulsories = 6 units
 - 1 Squad Freestyle = 6 units
 - b) Individual Trot Event:
 - 1 Compulsories = 1 unit
 - 1 Freestyle = 1 unit
 - c) Pas de Deux Trot Events:
 - 1 Freestyle = 1.5 units
 - d) Squad Two-Phase Trot Event:—
 - 1 Squad **Two-Phase** Compulsories = 4 units
 - e) **Any Unrecognized classes including Squad, Pas de Deux and Individual**
 - **1 Vaulters = 1 unit**
3. Green Horse Class
 - a) For any entry regardless of gait - 1 Trot unit

Exception: If a horse is used at Trot/Canter or Walk/Canter on the same day, a maximum of 18 units is allowed.
NOTE: If there are multiple competitions in a single day, the daily maximum for both competitions is as listed above.
4. In All Recognized National Events, horses may be changed between sections of the event.
5. After the maximum number of units allowed, additional vaulters will be disqualified. The club which entered the horse in violation will be fined \$50 per violation.
6. Competitors may start on their own horse or another horse that is loaned to them.
7. Horses may be substituted until one (1) hour before the start of the competition, or at the discretion of competition management.

Article 304. Horse Inspection.

1. At National Championships, before the start of competition, there will be a vet check. The veterinarian, accompanied by at least one (1) member of the Ground Jury, preferably the President of the Ground Jury, will inspect the horses. (See Article 210.2 for definition of Ground Jury).
 - a) The horses will be presented in hand in a bridle with an easily visible number on the right side of the bridle. The veterinarian has the right to eliminate a horse for being lame or in bad condition. In case of disagreement, the member of the Ground Jury will make the final decision, which will be announced immediately.
 - b) There may be no objection against the decision of the Ground Jury. A reason for elimination must be given.
2. In addition, the Judge at A in each arena has the authority at any time during a competition to **eliminateexcuse** a horse which is uneven and/or un-level, in bad condition, or which shows signs of discomfort or fatigue.

Article 305. Equipment.

1. Required: All equipment must be used without changing the purpose of its manufactured state.

- a) Bridle with noseband or lungeing cavesson (which may be used instead of a bridle and may be used with or without a snaffle).
 - Padding is allowed on bridles
 - Except for the buckles and padding the headstall and noseband must be made entirely of leather or leather-like material
 - b) Snaffle bit
 - Bits must have a smooth surface, twisted and wire bits are prohibited.
 - Bits must be made of metal, rigid plastic or durable synthetic material and may be covered with rubber /latex.
 - Bits may have up to two (2) joints, unjointed bits must be made from flexible rubber to synthetic material.
 - Rubber bit guards are permitted.

See Annex 1 of the current FEI Rule for Vaulting for visuals on acceptable bridles and bits.
 - c) Two (2) side reins or two (2) 3-point reins.
 - Side reins are to be attached to the bit or cavesson and one (1) point of contact on the surcingle.
 - 3-point reins are attached from the surcingle through the bit rings back to the surcingle on the same side. The distance between the two attached points (top and bottom) on each side of the surcingle must not be greater than 40 centimeters (approximately 15.75 inches). The 3-point reins must be made of stretchable nylon or stretchable nylon/leather material and adjustable only as per manufacture. The 3-point reins may only be used in their manufactured state with no modifications to the adjustment points (for example making a knot is not allowed). 3-point reins may not be used while riding. Standing reins or auxiliary reins are not permitted. The horse's head should be at vertical or slightly ahead. See the FEI Rules for Vaulting Article 719.2.5.
 - d) Vaulting surcingle (preferably with wither and girth padding). The surcingle has two solid handles with two loops, one on each side. One short extra strap made of leather, may be fixed between the inner edges of the right and left handle. This strap may be wrapped with material suitable to provide protection from injury.

See the current FEI Rules for Vaulting Article 719.2.6 for visuals and additional information on acceptable surcingle design and measurements.
 - e) The back pad must be made out of materials which conforms itself to the horse's back (which may be checked by the Steward, Technical Delegate and/or a Judge at any time), one gel pad is allowed in addition to the back pad. The pad must adhere to the following dimensions:
 - Max. 80 cm from back edge of the surcingle to the back edge of the pad (approximately 31.5").
Note: for smaller horses pad may not extend beyond the point of the croup.
 - Max. 30 cm from front edge of the surcingle to the front edge of the pad (approximately 11.8")
 - Max. 90 cm from side to side the lowest point to the lowest point (approximately 35.4")
 - Max. 4.0 cm tick including cover (approximately 1.6")
 - Max total length 110 m, with no more than 30cm in front of the surcingle (approximately 3.6' and 11.8")
 - If checked on the horse, the tolerance may not exceed 3cm (approximately 1.2")
 - f) Lunge line - **May only be attached to the bit or cavesson. May not go through any point on the side reins or surcingle.**
 - g) Lunge whip
2. Optional:
 - a) Bandages, protection boots
 - b) Breast collar or breast plate
 - c) Ear hoods and plugs
 3. No auxiliary equipment is allowed.
 - a) Standing reins or auxiliary reins are not permitted.
 - b) The use of any equipment other than described above will entail elimination.

CHAPTER IV. RECOGNIZED NATIONAL EVENTS

Article 401. Definitions.

1. **Compulsories:** A set of required vaulting exercises judged on: Mechanics, Essence, Form, Scope, Security, Balance, Continuity, and Harmony with the Horse. Compulsory exercises are described in the current FEI Guidelines for Judges.
 2. **Freestyle:** A routine of static and dynamic exercises. The allotted time varies and is defined in each class section.
 3. **Technical Test:** The Technical Test is a one (1) minute (maximum) routine consisting of five (5) technical exercises and additional freestyle exercises chosen by the vaulter. For deductions and scoring of the Technical Test, see the current FEI Guidelines for Judges.
 4. **Modified Technical Test:** The Modified Technical Test is a one (1) minute (maximum) routine consisting of any three (3) of the five (5) current technical exercises and additional freestyle exercises chosen by the vaulter. For deductions and scoring see the current FEI Guidelines for Judges.
 5. **Technique: Score consists of Performance (70%) and DOD (30%):**
NOTE: For classes with no DOD component, Performance only is Technique
 - a) Performance:
 - Mechanics, essence, form, scope, security, balance, continuity and harmony with the horse
 - The average of deductions for every exercise and transition is deducted from the maximum score of 10.0.
 - Deductions for falls are deducted from the Performance Score at the end (not averaged).
 - b) Degree of Difficulty (DOD):
 - DOD is judged on height off horse, complication of the movements, demands of suppleness, stretch and timing, number of security and holding points, changes in direction (forward, backward, access), changes in relation to the horse (on neck, on croup, inside, outside).
 - See FEI Code of Points for additional information.
 6. **Artistic:** The Artistic score is comprised of:
 - a) Consideration of Horse (CoH)
 - Selection of elements and sequences to be in harmony with the horse based on weight, composition and balance.
 - Exercises not overweighing the horse.
 - b) Exercise variety (C1):
 - Use of varied structure groups (ex. lying, standing, strength exercises, flexibility exercises, rolls, swings, etc.).
 - Use of both static and dynamic exercises.
 - c) Space/Position variety (C2):
 - Balanced use of location (ex. back, neck, croup, grips, etc.)
 - Balanced use of direction (ex. inside facing, backward facing, rolling across the horse, etc.)
 - d) Unity (C3):
 - Balanced and smooth transitions and movements
 - Selection of exercises are appropriate for the horse and vaulter
 - Movements and exercises are controlled and harmonious
 - Complexity of exercises, sequences, transitions, and combinations (1* Bronze and above).
 - e) Music Interpretation (C4):
 - Ability to engage and captivate using a musical platform
 - Expression of the musical elements
 - Complexity of body language
- For more information regarding the Artistic score, please refer to the FEI Guideline for Judges.*
7. **Canter Horse Score:**
 - a) A1 - Quality of the gait and thoroughness
 - Rhythm
 - Relaxation
 - Connection
 - Impulsion
 - Straightness
 - Collection
 - b) A2 - Vaultability of Horse

- Willingness and obedience
- Balance in tempo
- Balance in circling
- c) A3 - Lunging
 - Easy and effortless communication between lunger and horse
 - Entry, salute and trot round

For more information regarding the Horse score, refer to the FEI Guidelines for Judges.

8. Trot Horse Score:

- a) A1 - Quality of the gait and throughness
 - Rhythm
 - Relaxation/Suppleness
 - Connection
 - Straightness
- b) A2 - Vaultability of Horse
 - Willingness and obedience
 - Balance in tempo
 - Balance in circling
- c) A3 - Lunging
 - Easy and effortless communication between lunger and horse
 - Entry, salute and trot round

For more information regarding the Trot Horse score, refer to Appendix D of the EVUSA Rules for Vaulting.

INDIVIDUAL EVENTS

Article 402. Individual Event Requirements - Compulsories.

1. All compulsories are performed as a unit.
2. All vaulters performing on the same horse should follow one another immediately without waiting for the bell. The next vaulter may not enter the competition circle until the first vaulter has commenced the dismount.
3. There is no time limit.
4. Judged on:
 - a) Performance
 - b) Horse
5. Falls:
 - a) The vaulter may continue after a fall. They must remount within one (1) minute in order to continue with the next exercise.
 - b) The unsuccessful exercise receives a zero (0) and may not be repeated.
6. See EVUSA Rules Chapter V. Scoring for penalties and deductions.

Article 403. Individual Event Requirements – Technical Test & Modified Technical Test

1. The technical exercises are from the following categories of motor skills:
 - a) Balance
 - b) Timing/Coordination
 - c) Strength
 - d) Jump Force
 - e) Suppleness
2. The exercises included in each category are described in the current FEI Guidelines for Judges.
3. All static technical exercises must be held three (3) canter strides or will receive a deduction of one (1) point for each stride held less than three (3).
4. Falls:
 - a) The vaulter may continue after a fall. They must remount within one (1) minute in order to continue with the next exercise.
 - b) If the fall is during a technical exercise, the unsuccessful exercise receives a zero (0) and may not be repeated.

Article 404. Individual Event Requirements – Freestyle.

1. Freestyle is a one (1) minute (maximum) routine of static and dynamic exercises.
2. Static exercises must be held for three (3) full canter strides in order to be counted in Degree of Difficulty and Artistic. A static exercise is one where contact, support or holding points do not change.
3. For 3*, 2* Young Vaulters/Gold, 2* Silver, and 1* Bronze:
 - a) The vaulter must stay in contact with the horse or surcingle except for leaps above the horse.
4. For 1* Copper and 1* Trot:
 - a) Vaulters must stay in contact with the horse. Ground jumps and leaps above the horse are NOT allowed and will receive a deduction if performed; hop from forward facing kneel to forward facing feet is allowed.
 - b) Only E dismounts, which land facing forward, are allowed. All other dismounts will receive a deduction if performed.
5. Falls:
 - a) The vaulter may continue after a fall. They must remount within one (1) minute in order to continue with the next exercise.
 - b) The unsuccessful exercise may be repeated.
6. See EVUSA Rules Chapter V. Scoring for penalties and deductions.

Article 405. 3* Individual Requirements.

1. 3* Level consists of one (1) round: Compulsories, Technical Test and Freestyle performed in separate sections.
2. Competition is at the canter to the left or to the right for Compulsory, Technical Test and Freestyle sections.
3. Women's and Men's divisions must be offered.

Article 406. 3* Individual Compulsories.

1. 3* Compulsories:
 - 1) Vault On
 - 2) Flag
 - 3) Mill
 - 4) Scissors 1st Part
 - 5) Scissors 2nd Part
 - 6) Stand
 - 7) First Part of Flank, Mill back to seat astride
 - 8) Swing off from seat astride to the outside

Article 407. 3* Individual Technical Test.

1. Judged On:
 - a) The maximum score is 10.0. Decimals are allowed
 - b) The Technical Test receives eight (8) scores:
 - Five (5) separate performance scores for the designated Technical exercises are given in addition to an average score for the performance of all the additional exercises. These six (6) scores are added together and divided by 6 (x50%).
 - Artistic (x25%)
 - Horse (x25%)
 - c) The three (3) scores are totaled.

Article 408. 3* Individual Freestyle.

1. Degree of Difficulty (DOD):
 - a) Only the ten (10) most difficult exercises with a DOD of R, D or M will be counted in the DOD score.
 - b) The maximum score for DOD is 10.0.
 - c) Value is as follows:

Risk (R) Exercises	1.3 points
Difficult (D) Exercises	0.9 points

Medium (M) Exercises	0.4 points
----------------------	------------

2. Judged on:

Technique	50%
Artistic	25%
Horse	25%

Article 409. Individual 2* Young Vaulters/Gold Requirements.

1. 2* Young Vaulters/Gold Level consists of one (1) round: Compulsories, Modified Technical Test and Freestyle performed in separate sections.
2. Competition is at the canter to the left or to the right for Compulsory, Modified Technical Test and Freestyle sections.
3. Women's and Men's divisions must be offered.

Article 410. 2* Young Vaulters/Gold Compulsories

1. 2* Young Vaulters/Gold Compulsories
 - 1) Vault On
 - 2) Basic Seat
 - 3) Flag
 - 4) Mill
 - 5) Scissors 1st Part
 - 6) Scissors 2nd Part
 - 7) Stand
 - 8) First Part of Flank, Push off to Inside

Article 411. 2* Young Vaulters/Gold – Modified Technical Test

1. The modified technical test is a one (1) minute routine consisting of any three (3) of the five (5) Technical exercises and additional Freestyle exercises chosen by the vaulter. The Technical exercises may be shown in any order. Only the first three (3) Technical exercises shown will be scored. Any other Technical exercises shown after the first three (3) will be scored as additional freestyle exercises.
2. The technical exercises are described in the current FEI Guidelines for Judges.
3. All static technical exercises must be held three (3) canter strides or will receive a deduction of one (1) point for each stride held less than three (3).
4. Falls:
 - a) The vaulter may continue after a fall. They must remount within one (1) minute in order to continue with the next exercise.
 - b) If the fall is during a technical exercise, the unsuccessful exercise receives a zero (0) and may not be repeated.
5. Judged on:
 - a) Maximum score is 10.0. Decimals are allowed.
 - b) The Technical Test receives six (6) scores:
 - Three (3) separate performance scores for the chosen Technical exercises are given in addition to an average score for performance of all additional exercises. These four (4) scores are added together and divided by four (4) (x50%).
 - Artistic (x25%)
 - Horse Score (x25%)
 - c) The three (3) scores are totaled.

Article 412. 2* Young Vaulters/Gold Freestyle

1. Degree of Difficulty (DOD):
 - a) Only the ten (10) most difficult exercises with a DOD of R, D or M will be counted in the DOD score.
 - b) The maximum score for DOD is 10.0.
 - c) Value is as follows:

Risk (R) Exercises	1.3 points
Difficult (D) Exercises	0.9 points

Medium (M) Exercises	0.4 points
----------------------	------------

2. Judged on:

Technique	50%
Artistic	25%
Horse	25%

Article 413. 2* Silver Event Requirements.

1. 2* Silver Level consists of one (1) round, Compulsories and two (2) Freestyles performed in separate sections.
 - a) Vaulters who hold Gold medals may not compete in the 2* Silver division.
2. For 2* Silver, Compulsories and Freestyle are performed at the canter to the left or to the right.
3. In the event there are more than thirty (30) competitors in the 2* Silver Event, Competition Management, at its discretion, may limit the number of competitors who compete in the second Freestyle.
4. Women’s and Men’s divisions must be offered.

Article 414. 2* Silver Compulsories.

1. 2* Silver Compulsories
 - 1) Vault On
 - 2) Basic Seat
 - 3) Flag
 - 4) Mill
 - 5) Scissors 1st Part
 - 6) Scissors 2nd Part
 - 7) Stand
 - 8) First Part of Flank, Push off to Inside

Article 415. 2* Silver Freestyle.

1. Degree of Difficulty (DOD):
 - a) Only the ten (10) most difficult exercises with a DOD of R, D or M will be counted in the DOD score.
 - b) The maximum score for DOD is 10.0.
 - c) Value is as follows:

Risk (R) Exercises	1.3 points
Difficult (D) Exercises	0.9 points
Medium (M) Exercises	0.4 points

d) Judged on:

Technique	50%
Artistic	25%
Horse	25%

Article 416. 1 * Bronze Event Requirements.

1. Consists of one (1) round: Compulsories, Freestyle and Compulsories to the Right performed in separate sections.
 - a) Vaulters who hold Gold or Silver medals may not compete in the 1* Bronze division.
2. For 1* Bronze, Round I of compulsories must be to the left, freestyle is at the canter to the left or to the right. Round II of compulsories is to the right. In the event there are more than thirty (30) competitors in the 1 * Bronze Event, Competition Management, at its discretion, may limit the number of competitors who compete in the Compulsories to the Right section. In this instance, the top fifteen (15) highest scoring women and the top fifteen (15) highest scoring men will advance to compete in the Compulsories to the Right section.
3. Women’s and Men’s divisions must be offered.

Article 417. 1* Bronze Compulsories.

1. Bronze Compulsories:
 - 1) Vault On
 - 2) Basic Seat
 - 3) Flag
 - 4) Stand
 - 5) Swing Forward
 - 6) 1/2 Mill
 - 7) Swing Backward, followed by dismount to inside

Article 418. 1* Bronze Freestyle.

1. Degree of Difficulty (DOD):
 - a) All exercises with a DOD of D, M or E will be counted in the DOD score. Note: 1* Bronze vaulters may perform R exercises but will only be given D credit for them.
 - b) The maximum score for DOD is 9.0.
 - c) Value is as follows:

Difficult (D) Exercises	0.9 points
Medium (M) Exercises	0.4 points
Easy (E) Exercises	0.3 points

2. Judged on:

Technique	50%
Artistic	25%
Horse	25%

Article 419. 1* Copper Event Requirements

1. 1* Copper Level consists of one (1) round: Compulsories and Freestyle performed in separate sections.
 - a) Vaulters who hold any canter medal higher than the Copper medal may not compete in the 1* Copper division.
2. Competition is at the canter to the left or to the right for Compulsory and Freestyle sections.
3. Woman's and Men's divisions must be offered.

Article 420. 1* Copper Compulsories.

1. Copper Compulsories:
 - 1) Vault On
 - 2) Basic Seat
 - 3) Flag
 - 4) Stand
 - 5) Swing Forward
 - 6) 1/2 Mill
 - 7) Swing Backward, followed by dismount to inside (quarter mill around to inside off)

Article 421. 1* Copper Freestyle.

1. Judged on:

Technique	X3
Artistic	X2
Horse	X1

Article 422. 1* Trot Event Requirements.

1. 1* Trot Level consists of one (1) round: Compulsories and Freestyle performed in separate sections.
 - a) Open to Trot medal holder or below.
2. Competition is at the trot to the left or to the right for Compulsory and Freestyle sections.
3. Vaulters must receive a boosted mount at the trot in both the Compulsory and Freestyle sections.
4. Women's and Men's divisions must be offered.

Article 423. 1* Trot Compulsories

1. Trot Compulsories:
 - 1) Boosted Vault On (Not scored)
 - 2) Basic Seat
 - 3) Flag
 - 4) Stand
 - 5) Swing Forward
 - 6) 1/2 Mill
 - 7) Swing Backward, followed by dismount to inside

Article 424. 1* Trot Freestyle

1. Judged on:

Technique	X3
Artistic	X2
Horse	X1

PAS DE DEUX EVENTS

Article 425. Pas de Deux Event Requirements.

1. Pas de Deux event is composed of two (2) vaulters of any combination of male and female.
2. 2* Canter and 3* Canter Pas de Deux divisions offered consist of one (1) or two (2) rounds of Freestyle (at discretion of competition management).
3. 1* Canter and 1* Trot Pas de Deux consist of one (1) round of Compulsories and Freestyle.
4. All Pas de Deux sections may be performed to the left or to the right.
5. Pas de Deux requirements and vaulter restrictions:
 - a) 3* Canter and 2* Canter - No restrictions apply, any level vaulter may compete in this division.
 - b) 1* Canter – Neither vaulter may hold a Gold medal. No more than one (1) vaulter may hold a Silver medal nor compete or ever have competed at 2* Silver.
 - c) 1* Trot - Open to vaulters who do not hold any canter medals nor are vaulting at the same competition in any EVUSA Recognized Canter classes.
 - d) Falls:
 1. Vaulter(s) may continue after a fall. If both vaulters lose contact with the horse, the clock will be stopped and they must remount within one (1) minute in order to continue. Time will be restarted when the first vaulter touches the grips. See EVUSA Rules Chapter V. Scoring for penalties and deductions.
 2. The unsuccessful exercise may be repeated.

Article 426. 3* Canter and 2* Canter Pas de Deux Event Requirements.

1. Static exercises must be held for three (3) full strides at the appropriate gait. A static exercise is one where contact, support or holding points do not change.
2. Both vaulters must stay in contact with the horse, surcingle or each other. Ground jumps, leaps and exercises above the horse are allowed.
3. Exercises to be counted in Degree of Difficulty (DOD) are:
 - a) The mount and dismount of each vaulter
 - b) Double exercises.
 - c) If two (2) static exercises are performed simultaneously, only the most difficult one is scored.
 - d) If one (1) static and one (1) dynamic exercise are performed simultaneously, and the vaulters are not in contact with each other, each exercise receives a score.
 - e) If two (2) dynamic exercises from different structure groups are performed, each exercise receives a score.
 - f) Aside from the mount and dismount, no exercise with only one (1) vaulter on horse receives a score.

Article 427. 3* Canter Pas de Deux Freestyle.

1. Freestyle is a two (2) minute (maximum) routine of static and dynamic exercises with no requirements or limitations.
2. Competition is at the canter to the left or to the right for Freestyle.

3. Degree of Difficulty (DOD):
 - a) Only the thirteen (13) exercises with the highest DOD of D or M will be scored.
 - b) Maximum DOD is 10.0.
 - c) Value is as follows:

Difficult (D) Exercises	0.8 points
Medium (M) Exercises	0.4 points
Easy (E) Exercises	0.0 points

4. Judge on:

Technique	50%
Artistic	25%
Horse	25%

Article 428. 2* Canter Pas de Deux Freestyle.

1. Freestyle is a one and a half minute (90 seconds) (maximum) routine of static and dynamic exercises with no requirements or limitations.
2. Competition is at the canter to the left or to the right for Freestyle.
3. Degree of Difficulty (DOD):
 - a) Only the ten (10) exercises with the highest DOD of D or M will be scored.
 - b) Maximum DOD is 10.0.
 - c) Value is as follows:

Difficult (D) Exercises	1.0 points
Medium (M) Exercises	0.5 points
Easy (E) Exercises	0.0 points

4. Judged on:

Technique	50%
Artistic	25%
Horse	25%

Article 429. 1* Canter and 1* Trot Pas de Deux Event Requirements.

1. Consists of two (2) rounds; Compulsories and Freestyle performed to the left or to the right.
2. Compulsories are performed by each member of the Pas de Deux as in 1* Squad event. Vaulters should follow one another immediately, there is no deduction for subsequent vaulters entering the circle while a previous vaulter is performing compulsories. There is no time limit for compulsories.
3. Freestyle is a one and a half minutes (90 seconds) (maximum) routine of static and dynamic exercises.
 - a) 1* Canter has no requirements or limitations
 - b) 1* Trot has the following limitations:
 - Trot vaulters must receive a boosted mount at the trot for both compulsories and freestyle, in freestyle the first vaulter is boosted from the ground, the second vaulter may be lifted onto the horse by the 1st vaulter or receive a boost from the ground.
 - Only E dismounts which land facing forward are allowed. (See Article 503.2)
 - Vaulters must stay in contact with the horse or each other. Ground jumps and unsupported leaps are not allowed. (See Article 503.2)

Article 430. 1* Canter Pas de Deux Freestyle.

1. Freestyle is a one and a half minute (90 seconds maximum) routine of static and dynamic exercises with no requirements or limitations.
2. Competition is at the canter to the left or the right for Freestyle.
3. Judged on:

Performance	50%
Artistic	25%
Horse	25%

Article 431. 1* Trot Pas de Deux Freestyle.

1. Freestyle is a one and a half minute (90 seconds maximum) routine of static and dynamic exercises with no requirements or limitations.
2. Competition is at the trot to the left or the right for Freestyle.
3. Judged on:

Technique	X3
Artistic	X2
Horse	X1

TWO-PHASE SQUAD EVENTS

Article 432. Two-Phase Squad Event Requirements.

1. This Two-Phase event is performed in two (2) separate sections.
2. Phase 1 is Compulsories and is performed on the horse to the right; Phase 2 is a Freestyle and is performed on the barrel.
3. Squads shall consist of four (4) vaulters, optional substitute and a lunger.
4. Divisions requirements and vaulter restrictions:
 - a) 2* Canter
 - No restrictions apply.
 - b) 1* Canter
 - One vaulter may hold a Silver medal.
 - c) 1* Trot
 - Open to vaulters who do not hold any canter medals nor are vaulting at the same competition in any EVUSA Recognized Canter classes.

Article 433. Two Phase Squad Event: Phase 1 — Horse.

1. Each vaulter, including the substitute, must perform all compulsory exercises to the right. There is no time limit.
2. Each exercise is performed as in the Squad Event except that the exercises are mirror images of the exercises to the left. Vaulters should follow one another immediately, there is no deduction for subsequent vaulters entering the circle while the previous vaulter is performing compulsories.
 - a) For 2* Canter Division, the compulsory exercises are as in 2* B Squad.
 - b) For 1* Canter Division, the compulsory exercises are as in 1* C Squad.
 - c) For 1* Trot Division, the compulsory exercises are as in 1* Trot Squad and all vaulter must receive a boosted mount at the trot.
3. All rules which apply to the Compulsory section of the Squad Canter Event also apply to this phase.
4. Judged on:
 - a) Performance
 - b) Horse

Article 434. Two Phase Squad Event: Phase 2 — Barrel.

1. Three (3) minute Freestyle routine performed on the barrel.
2. Only four (4) vaulters are allowed to enter the arena for the Freestyle. The Squad coach must declare to competition management, by the time specified by competition management, which members of the Squad will perform in the Freestyle. All Squad members, as declared by the coach, must perform in the Freestyle or the Squad will receive a deduction in the Artistic score (see Article 503.2).
3. All applicable rules for judging Squad Freestyle will apply (See Article 442.4 and 442.6-7). There are no restrictions on what type of exercises may be performed. No other equipment or attachments to the barrel are allowed. No more than three (3) vaulters may be in an exercise at any time.
4. Judged on:

Technique	X3
Artistic	X2
Consideration of Barrel & General Impression <ul style="list-style-type: none">• See Guidelines Appendix D & E for description and reference scores.	X1

5. See EVUSA Rules Chapter V. Scoring for penalties and deductions.

SQUAD EVENTS

Article 435. Recognized National Squad Event Requirements (3* A, 2* B, 1* C and 1* Trot).

1. Consists of one (1) round of Compulsories and Freestyle performed in separate sections.
2. Squad Canter Event:
 - a) The Compulsory and Freestyle section is performed at canter and may be to the left or to the right.
3. Squad 1* Trot Event:
 - a) The Compulsory and Freestyle section is performed at trot and may be to the left or to the right.

Article 436. Squad Eligibility.

1. Squads are comprised of six (6) vaulters, an optional substitute, and a lunger. All vaulters, including the substitute and lunger, must be members of registered EVUSA clubs in good standing.
2. **Canter Divisions:** Divided into 3* A, 2* B and 1* C divisions. A vaulter may not compete at the same competition at more than one (1) level of National Squad Event.
 - a) For purposes of Squad Canter Event, vaulters shall carry the following classification:
 - Class A
 - i. A vaulter who holds a Gold medal
 - Class B
 - i. A vaulter who holds a Silver medal
 - Class C
 - i. A vaulter who holds a Copper or Bronze medal
 - ii. A vaulter who is unrated
 - b) No more than three (3) Class A vaulters may compete on a 2* B Squad, including the substitute.
 - c) No more than three (3) Class B vaulters may compete on a 1* C Squad including the substitute.
 - d) A vaulter's Squad classification (A, B or C) is as of the closing date of entries of the competition.
3. **1* Trot Division:** No vaulter may hold a medal higher than a Trot medal, including the substitute. Vaulters may not compete elsewhere in the same competition at the canter in an EVUSA Recognized class in the same competition (i.e. Trot squad and D Canter would be acceptable).

Article 437. Squad Compulsories.

1. For all Squad compulsories, each vaulter, including the substitute, must perform the Compulsories together. Vaulters should follow one another immediately, there is no deduction for subsequent vaulters entering the circle while a previous vaulter is performing compulsories.
2. Judged on:
 - a) Performance
 - b) Horse
3. Time for the Compulsories is taken from the moment the first vaulter touches the grips, until the last vaulter to perform touches the ground in the dismount or at the end of the time limit. The Judge at A will ring a bell signifying the end of time allowed. Compulsory exercises begun after the time limit will receive a score of zero (0).
4. Each of the six (6) Squad members plus the substitute must perform all compulsory exercises.
5. Each vaulter must vault in order, according to their number.
6. Each static compulsory exercise must be held for four (4) full strides.

Article 438. 3* A Squad Compulsories.

1. Time Limit: If a 3* A Squad does not include a substitute, the maximum time allowed for the performance of the Compulsory Test is six (6) minutes. If a substitute enters the arena with the Squad, they must perform the Compulsory Test and the maximum time allowed for the performance is seven (7) minutes.
2. Exercises:
 - 1) Vault On
 - 2) Flag
 - 3) Mill
 - 4) Scissors 1st Part
 - 5) Scissors 2nd Part
 - 6) Stand
 - 7) Flank 1st part, Push off to Inside Mill back to seat astride
 - 8) Swing off from seat astride to the outside

Article 439. 2* B Squad Compulsories.

1. Time Limit: If a 2* B Squad does not include a substitute, the maximum time allowed for the performance of the Compulsory Test is six (6) minutes. If a substitute enters the arena with the Squad, they must perform the Compulsory Test and the maximum time allowed for the performance is seven (7) minutes.

2. Exercises:
 - 1) Vault On
 - 2) Basic Seat
 - 3) Flag
 - 4) Mill
 - 5) Scissors 1st Part
 - 6) Scissors 2nd Part
 - 7) Stand
 - 8) First Part of Flank, Push off to Inside

Article 440. 1* C Squad Compulsories.

1. Time Limit: If a 1* C Squad does not include a substitute, the maximum time for the performance of the Compulsory Test is five (5) minutes. If a substitute enters the arena with a 1* C Squad, they must perform the Compulsory Test and the maximum time allowed for the performance is six (6) minutes.
2. Exercises:
 - 1) Vault On
 - 2) Basic Seat
 - 3) Flag
 - 4) Stand
 - 5) Swing Forward
 - 6) 1/2 Mill
 - 7) Swing Backward, followed by dismount to inside

Article 441. 1* Trot Squad Compulsories.

1. Time Limit: If a 1* Trot Squad does not include a substitute, the maximum time allowed for the performance of the Compulsory Test is six (6) minutes. If a substitute enters the arena with the Squad, they must perform the Compulsory Test and the maximum time allowed for the performance is seven (7) minutes.
2. Exercises:
 - 1) Boosted Vault On (not scored)
 - 2) Basic Seat
 - 3) Flag
 - 4) Stand
 - 5) Swing Forward
 - 6) 1/2 Mill
 - 7) Swing Backward, followed by dismount to inside

Article 442. Canter Squad Freestyle.

1. For 3* A and 2* B Freestyle, a routine of three and a half (3.5) minutes maximum is performed by the Squad of six (6) vaulters.
2. For 1*C, a Freestyle of three (3) minutes maximum is performed by the Squad of six (6) vaulters.
3. The coach must declare to competition management, by the time specified by competition management, which members of the Squad will perform in Freestyle. The vaulters Squad numbers for Freestyle must remain the same as their numbers used for Compulsories. Only six (6) vaulters are allowed to enter the arena for Freestyle.
4. All Squad members as declared by the coach must perform in the Freestyle or the Squad will be penalized under Artistic. (See Article 503.2)
5. Freestyle time begins when the first vaulter touches the grips and ends when the bell rings to indicate the end of time allowed, or when the last vaulter touches the ground.

6. Over weighting or overloading the horse will be penalized under Artistic. (See Article 503.2)
7. No more than three (3) vaulters may be on the horse at any time, or in any exercise whether actually on the horse or not. (See Article 504.2.i)
8. For 1* C, only single and double exercises are allowed, triple exercises are not allowed.
9. There must be at least two (2) vaulters in contact with the horse during any triple exercise for the exercise to be counted.
10. Each static Freestyle exercise must be held for three (3) full strides in order to be counted in Degree of Difficulty. A static exercise is one where contact, support or holding points do not change. The count for each exercise commences when the final position is attained.
11. Falls:
 - a) Vaulter(s) may continue after a fall. If all vaulters lose contact with the horse, the clock will be stopped.
 - b) The clock will be stopped for a maximum of one (1) minute for each fall. It will be restarted when the first vaulter touches the grips.
 - c) The unsuccessful exercise may be repeated.
12. See EVUSA Rules Chapter V. Scoring for penalties and deductions.

Article 443. 1* Trot Squad Freestyle.

1. A Freestyle routine of three (3) minutes maximum is performed by the Squad of six (6) vaulters.
2. Only six (6) vaulters are allowed to enter the arena for Freestyle. The coach must declare to competition management, by the time specified by competition management, which members of the squad will perform in Freestyle. The vaulters squad numbers for Freestyle must remain the same as their numbers used for Compulsories.
3. Vaulters must stay in contact with the horse or each other. Ground jumps and unsupported leaps are not allowed and will receive a deduction in the Artistic score. (See Article 503.2)
4. Only E dismounts which land facing forward are allowed (See Article 503.2)
5. All mounts must be performed at the trot and be boosted from either the ground or aided by vaulter(s) already on the Horse.
6. All other rules from Canter 1*C Squad Freestyle apply.
7. For 1* Trot Squad, only single and double exercises are allowed, no triple exercises are allowed.
8. See EVUSA Rules Chapter V. Scoring for penalties and deductions.

Article 444. 3* A Squad Freestyle:

1. Degree of Difficulty (DOD):
 - a) Only the twenty-five (25) exercises with the highest DOD will be scored.
 - b) Value is as follows:

Difficult (D) Exercises	0.4 points
Medium (M) Exercises	0.3 points
Easy (E) Exercises	0.1 points

2. Judged on:

Technique	50%
Artistic	25%
Horse	25%

Article 445. 2* B Squad Freestyle:

1. Degree of Difficult (DOD):
 - a) Only the twenty (20) exercises with the highest DOD will be scored.
 - b) Value is as follows:

Difficult (D) Exercises	0.5 points
Medium (M) Exercises	0.4 points
Easy (E) Exercises	0.2 points

2. Judged on:

Technique	50%
Artistic	25%
Horse	25%

Article 446. 1* C Squad Freestyle.

1. No triples are allowed. (See Article 503.2).
2. There is no Degree of Difficulty score.
3. The performance of all freestyle exercises will be evaluated.
4. Judged on:

Technique	50%
Artistic	25%
Horse	25%

Article 447. 1* Trot Squad Freestyle.

1. No triples are allowed. (See Article 503.2).
2. There is no Degree of Difficulty score.
3. The performance of all freestyle exercises will be evaluated.
4. Judged on:

Technique	X3
Artistic	X2
Horse	X1

CHAPTER V. SCORING

Article 501. Judging Code. (Listed in alphabetical order by term).

AL - Alignment	SH - Shoulders
A/L - Arm & Leg	SS - Side Seat
AB - Arched Back	SL - Slow
A - Arms	ST - Stiff
B - Balance	SX - Stretch
CS - Chair Seat	SP - Suppleness
CH - Chin	SW - Swing
C - Collapse	TL - Tilting
CD - Come Down	TW - Time Wasted
CT - Control	T - Timing
D - Dismount	TZ - Toes
DL - Down Leg	TG - Touched Ground
E - Elevation	TH - Touched Horse
X - Extension	TN - Touched Neck
O - Fall	TI - Turned In
OD - Fall on Dismount	UE - Uneven Elevation
FP - Flight Phase	UR - Uneven Rhythm
FT - Feet	UW - Uneven Width
FL - Flight	W - Wrap
F - Form	
FK - Frog Kick	
FH - Front High	
GJ - Ground Jump	
HA - Handles	
HZ - Hands	
HM - Harmony	
H - Head	
HH - Hit Horse	
HK - Hook	
INT - Interruption	
K - Kneel	
KZ - Knees	
LH - Lands Heavily	
LD - Late Dismount	
LT - Late Turn	
L - Legs	
LA - Legs Apart	
LF - Legs Forward	
MX - Mechanics	
M - Mount	
NT - No Turn	
NC - Not Clear of Horse	
NH - Not Held	
OC - Off Center	
OH - Off Horse	
PD - Pad	
PT - Partial Turn	
PE - Pelvis Pushed Up	
PK - Pike	
PL - Poor Landing	
P - Posture	
PB - Push Back	
PO - Pushing of Horse	
Q - Quick	
R - Repeat	
RB - Rounded Back	
SC - Scope	
SK - Security	

COMMENTS FOR HORSE SCORE:

BH - Behavior
LW - Linger Walking
CS - Circle Size
SB - Submission
GT - Gait
TM - Tempo

Article 502. Points and Values.

10 - Excellent
9 - Very Good
8 - Good
7 - Fairly good
6 - Satisfactory
5 - Marginal
4 - Insufficient
3 - Fairly Poor
2 - Poor
1 - Very Poor
0 - Not Performed (or as a result of deductions)

1. Scoring may be in tenths for all events including medal examinations. The maximum score is 10.0
2. Scores are rounded to the third decimal.
3. For further information about scoring particular events, see Section 503 – 504 of this chapter. See also Standing Rules, Section VIII Recognized Competitions – E. Scoring.

Article 503. Penalties and Deductions.

1. Compulsory Penalties and Deductions:

Applies to All Compulsory Exercises

1 point deduction	<ul style="list-style-type: none"> Interfering with the lunge line or side reins.
Up to 2 point deduction	<ul style="list-style-type: none"> Time wasted: more than two (2) strides between taking grips and vaulting on, before commencing an exercise, and between parts of an exercise. Landing heavily on horse's back
2 point deduction	<ul style="list-style-type: none"> Exercise fails, repeating an exercise or part of an exercise
Score of Zero (0)	<ul style="list-style-type: none"> Coming off horse during a compulsory exercise Retaking the grips twice A compulsory exercise, no part of which is performed at the required gait Each compulsory exercise not performed A compulsory exercise shown out of order. When two compulsories are transposed, the first exercise performed out of order receives the zero (i.e. If a vaulter performs Mill, then Flag, the Mill receives the zero) In Squad Events, exercises begun after the time limit. In any 1* Trot class with Compulsories, all Compulsories for that vaulter if the vaulter does not receive a boosted mount.

Mount

2 point deduction	<ul style="list-style-type: none"> Repeating Mount (first attempt unsuccessful, second attempt successful)
Score of Zero (0)	<ul style="list-style-type: none"> Repeating Mount (attempting to mount twice but not successful; third attempt is successful, but receives the zero) In Squad Events, after third unsuccessful attempt to mount, the vaulter returns to the line and receives a zero for all compulsory exercises. The next Squad member proceeds
Elimination	<ul style="list-style-type: none"> In Individual Events, after third unsuccessful attempt to mount, the vaulter is excused from the ring.

Basic Seat

2 point deduction	<ul style="list-style-type: none"> Retaking grips In 1* Trot for boosted mount performed at any gait other than Trot (deduction taken from Basic Seat) In 1* Trot for repeating the Mount
Up to 3 point deduction	<ul style="list-style-type: none"> For landing heavily on Horse's back after boosted mount (deduction taken from Basic Seat)

Flag

1 point deduction	<ul style="list-style-type: none"> Each stride less than four (4) Touching neck without loss of form No kneel (both knees) before Flag.
Up to 1 point deduction	<ul style="list-style-type: none"> Arm and leg not raised simultaneously in flag.
2 point deduction	<ul style="list-style-type: none"> Retaking grips

Mill and Half Mill

1 point deduction	<ul style="list-style-type: none">• Each passing of the leg out of a 4-count rhythm in the Mill, including the dismount.• Rhythm failure between the first and second leg pass in Half-Mill
Up to 2 point deduction	<ul style="list-style-type: none">• Buttocks leaving horse during any phase of the Mill or Half Mill
2 point deduction	<ul style="list-style-type: none">• Touching horse with hand behind surcingle in Mill or Half-Mill

Scissors 1st Part and 2nd Part

Score of Zero (0)	<ul style="list-style-type: none">• Turning wrong way in the Scissors 1st part or Scissors 2nd part.
2 point deduction	<ul style="list-style-type: none">• Repeating the exercises after failed attempt

Stand

1 point deduction	<ul style="list-style-type: none">• Each stride less than four (4)• No kneel (both knees) before Stand.
2 point deduction	<ul style="list-style-type: none">• Retaking the grips

Flank

Up to 1 point deduction	<ul style="list-style-type: none">• Each landing other than on both feet.
2 point deduction	<ul style="list-style-type: none">• Repeating the exercises after failed attempt

Swing Forwards and Swing Backwards

2 point deduction	<ul style="list-style-type: none">• Repeating the exercises after failed attempt
-------------------	--

2. Freestyle and Technical Test Penalties and Deductions:

Performance

Up to 1 point deduction	<ul style="list-style-type: none">• In Squad Events, for each landing other than on both feet (See FEI Guidelines 3.5 Performance Falls for definition and deductions).
1 point deduction	<ul style="list-style-type: none">• In 3* Individual Technical Test and 2* Young Vaulters/Gold, each stride held less than three (3) for Technical Exercises.
Up to 2 point deduction	<ul style="list-style-type: none">• Falls (See FEI Guidelines 3.5 Performance Falls for definition and deductions).
Score of zero (0)	<ul style="list-style-type: none">• A zero (0) will be given for Performance for any 1* Trot freestyle class in which any or all vaulter(s) do not receive a boosted mount.

Artistic

1 point deduction	<ul style="list-style-type: none"> In all Events, any exercise (including the dismount) commenced after the time limit (Article 207.1) In Individual 1* Copper, 1* Trot, 1* Trot Pas de Deux and 1* Trot Squad for performing dismounts other than E dismounts which land facing forward. In 1* C Squad, and 1* Trot Squad for performing any triples.
Up to 2 point deduction	<ul style="list-style-type: none"> In Squad Event, overweighting and/or overloading the horse.
2 point deduction	<ul style="list-style-type: none"> In Squad Event, each vaulter not performing at least one (1) exercise in addition to the vault-on in Squad Freestyle. Ground jumps and leaps in Individual 1* Copper, Individual 1* Trot Event, 1* Canter Pas de Deux, 1* Trot Pas de Deux, and 1* Trot Squad.
Not scored	<ul style="list-style-type: none"> Each static exercise held for less than three (3) strides at the required gait Compulsory exercises An exercise no part of which is performed at the required gait Repetition of any exercise In Squad Event, a triple exercise in which two (2) vaulters are not in contact with the horse

Horse Penalties and Deductions

Judges Discretion	<ul style="list-style-type: none"> Lack of balance Not straight on the circle Impure gaits Uneven and/or un-level Poor condition Overloading, laboring, signs of discomfort Circle-size
Up to 1 point deduction	<ul style="list-style-type: none"> Audible instruction to vaulters Lunging and presentation Approaching the horse without the intention of mounting.
1 point deduction	<ul style="list-style-type: none"> In Squad Event, each Squad member not wearing a number.
Up to 2 point deduction	<ul style="list-style-type: none"> Lunging on a circle significantly deviant from 13 to 15 meters (circle size)
Up to 4 point deduction	<ul style="list-style-type: none"> Vaulter, lungers or horse inappropriately turned out Side reins forcing a horse's head behind the vertical All six (6) vaulters on a Squad not performing in the Freestyle Manes not braided or roached

Article 504. Elimination. Squad, Pas de Deux and Individual Events.

In the event of elimination, the judge must state their reason on the score sheet.

If a Squad, Pas de Deux or individual vaulter is eliminated for an infraction of the rules during any section of the event, they may compete in the other sections of the event and receive awards and placings in those sections. However, they may not receive overall awards or placings.

If the horse is excused for being uneven, un-level or for behavioral issues, the Judge at A will keep a log of such events. This list will remain at Table A even if there is a judge's rotation. If the competition has two (2) arenas in

use, the Judge at A in the Blue Arena will make sure the Judge at A in the Red arena is notified as to which horse(s) have been dismissed and vice versa.

In individual competition, if a horse is excused for misbehavior, and a vaulter has touched the horse or grips to begin their performance, the vaulter is eliminated **from that section**. Vaulters also in the arena waiting to perform on that horse may be allowed to compete at a later time, on a different horse, at the discretion of the competition management and in accordance with the rules. The horse is excused from that go only and may return if entered in the same class or subsequent classes.

1. Individual

- a) In Individual Event, if vaulter enters circle before previous vaulter begins vault off, entering vaulter will be eliminated.

2. Squad

- a) In **National** Squad Event, entering the ring with more or less than a lunger, Squad of six (6) and one (1) substitute for the compulsory section.
- b) In Squad Event, entering the ring with more or less than a lunger and a Squad of six (6) for the freestyle section.
- c) In Squad Event, the substitute enters the ring but does not perform the Compulsories.
- d) In Squad Two-Phase Event, entering the ring with more or less than a lunger, Squad of four (4) and one (1) substitute for the compulsory section.
- e) In Squad Two-Phase Event, entering the ring with more or less than a Squad of four (4) for the barrel freestyle section.
- f) In Squad Two-Phase Event, the substitute enters the ring but does not perform the Compulsories
- g) Illegal use of substitute.
- h) More than three (3) vaulters on the horse at any one time or in any exercise whether actually on the horse or not.

3. All Events

- a) Abuse of Horse
- b) After the maximum number of vaulters allowed to use the horse in any day, all additional vaulters who performed on the horse will be disqualified from the class(es) in which the violation occurred
- c) Use of non-allowable equipment
- d) If a horse is excused after a vaulter touches the horse or grips to begin their performance, the vaulter/horse is eliminated for that class.
- e) Squad or vaulter not saluting the Judge at A within one (1) minute of the judge's signal to enter
- f) Vaulter leaves the arena without saluting the Judge at A (unless excused by judge)
- g) Squad or vaulter not commencing the performance within thirty (30) seconds of the judge's signal to begin
- h) An unforeseen circumstance
- i) Spotting and/or boosting from the ground, except in 1* Trot where a boost is required.
- j) Unauthorized assistance not specified elsewhere
- k) Use of dress other than defined

4. Horse Excusal ~~and Elimination~~

- a) **Uneven/Un-level:** If a horse is excused for being uneven or un-level, the horse may not return for subsequent goes within the same class.
 - i. If no vaulter in the arena has touched the horse and the competitive unit is excused, the vaulter(s) in that competitive unit may be allowed to compete in the same class at a later time, on a different horse, at the discretion of competition management and in accordance with the rules.
 - ii. If there are other competitive units on the same horse later in the class, they are allowed to compete but not on the horse that was excused.
 - iii. After one excusal, the horse may return in subsequent classes
 - iv. After two excusals on the same day, the horse is excused for the remainder of that day and may not return in subsequent classes.
 - v. If the competition is longer than one day, horses may be presented again in subsequent days.
- b) **Behavior:** If a horse is excused for behavior, they may return for subsequent goes within the same class
 - i. If no vaulter in the arena has touched the horse they may be allowed to compete in the same class at a later time on the same horse or a different horse, at the discretion of the competition management and in accordance with the rules.

- ii. A horse may be excused up to three (3) times for behavior. After the ~~third~~three excusals in the same day, the horse is excused for the remainder of that day and may not return in subsequent classes.
- iii. If the competition is longer than one day, horses may be presented again in subsequent days.

Article 505. 3* Individual, 2* Young Vaulters/Gold, 2* Silver and 1* Bronze Event Scoring.

1. 3* Individual:

a) Compulsory section (Score 1):

- The eight (8) compulsory scores are added and the total is divided by eight (8).

Compulsory Score	75%
Horse	25%

- The two (2) scores are totaled.

b) Technical Test Section (Score 2)

Five (5) Technical Exercise scores are added to the averaged performance score for the additional exercises. These six (6) scores are added together and divided by 6	50%
Artistic	25%
Horse	25%

- The three (3) scores are totaled.

c) Freestyle section (Score 3):

Technique	50%
Artistic	25%
Horse	25%

- The three (3) Freestyle scores are totaled.

d) Final score:

- All three (3) scores are added together and divided by three (3) to produce the final score.

2. 2* Young Vaulters/Gold

a) Compulsory section (Score 1):

- The eight (8) compulsory scores are added and the total is divided by eight (8).

Compulsory Score	75%
Horse	25%

- The two (2) scores are totaled.

b) Technical Test Section (Score 2)

Three (3) Technical Exercise scores are added to the averaged performance score for the additional exercises. These four (4) scores are added together and divided by 4	50%
Artistic	25%
Horse	25%

- The three (3) Freestyle scores are totaled.

c) Freestyle Section (Score 3)

Technique	50%
Artistic	25%
Horse	25%

- The three (3) Freestyle scores are totaled.

d) Final score:

- All three (3) scores are added together and divided by three (3) to produce the final score.

3. 2* Silver:

a) Compulsory section (Score 1 and 3):

- The eight (8) compulsory scores are added and the total is divided by eight (8).

Compulsory Score	75%
Horse	25%

- The two (2) scores are totaled.

b) Freestyle section (Score 2):

Technique	50%
Artistic	25%
Horse	25%

- The three (3) Freestyle scores are totaled.

c) Final score:

- All three (3) scores are added together and divided by three (3) to produce the final score.

4. 1* Bronze:

a) Compulsory section (Score 1 and 3):

- The seven (7) compulsory scores are added and the total is divided by seven (7).

Compulsory Score	75%
Horse	25%

- The two (2) scores are totaled.

b) Freestyle section (Score 2):

Technique	50%
Artistic	25%
Horse	25%

- The three (3) Freestyle scores are totaled.

c) Final score:

- All three (3) scores are added together and divided by three (3) to produce the final score.

Article 506. Individual 1* Copper and Individual 1* Trot Event Scoring

1. Compulsory section (Score 1)

- a) The seven (7) Compulsory scores for 1* Copper and the six (6) for 1* Trot are added and the total is divided by seven (7) or by six (6), respectively.

Compulsory Score	75%
Horse	25%

- The two (2) scores are totaled.

2. Freestyle section (Score 2)

Technique	X3
Artistic	X2
Horse	X1

- Total is divided by 6.

3. Final score:

- a) Scores 1 and 2 are added and divided by two (2) to produce the final score for the event.

Article 507. Pas de Deux Event Scoring—3* Canter and 2* Canter.

1. 3* Canter and 2* Canter Freestyle I and II (Score 1 and 2 if offered):

Technique	50%
Artistic	25%
Horse	25%

- The three (3) freestyle scores are totaled, and this is the score for the Freestyle section.

2. Final score (3* Canter and 2* Canter):

- a) Scores 1 and 2 (if offered) are added and divided by two (2) to produce the final score for the event if two (2) rounds are offered.
- b) If only one (1) round is offered the final score is the score for Freestyle I.

Article 508. Pas de Deux Event Scoring–1* Canter and 1* Trot.

1. Compulsory section (Score 1)

Compulsory Score	75%
Horse	25%

- a) The Compulsory scores of the two (2) vaulters are averaged, creating a single score for each of the Compulsory exercises. All averaged scores are added together and divided by the number of Compulsories (7 for 1* Canter PDD, 6 for 1* Trot PDD), to create the final Compulsory score

2. 1* Canter Freestyle section (Score 2):

Technique	50%
Artistic	25%
Horse	25%

3. 1* Trot Freestyle section (Score 2):

Technique	X3
Artistic	X2
Horse	X1

- Total is divided by six (6)

4. Final score:

- a) Scores 1 and 2 are added and divided by two (2) to produce the final score for the Event.

Article 509. Squad Two-Phase Event Scoring.

1. Compulsory section (Score 1):

Compulsory Score	75%
Horse	25%

- The two (2) scores are totaled.

- a) The compulsory scores of the four (4) vaulters are added creating a single score for each of the compulsory exercises.
- b) 2* Canter Squad: the eight (8) compulsory score sums are averaged for the four (4) vaulters by adding each of the (eight) 8 scores together and dividing by four (4), all averaged scores are added together and divided by eight (8) and make up 75% of the final score. The Horse score makes up 25% of the final score. Both scores are added to make up the final scores. This is the Squad's score for the compulsory section.
- c) 1* Canter Squad: the seven (7) compulsory score sums are averaged for the four (4) vaulters by adding each of the seven (7) scores together and dividing by four (4). All averaged scores are added together and divided by seven (7) and make up 75% of the final score. The Horse score makes up 25% of the final score. Both scores are added to make up the final scores. This is the Squad's score for the compulsory section.
- d) 1* Trot Squad: the six (6) compulsory score sums are averaged for the four (4) vaulters by adding each of the six (6) scores together and dividing by four (4), all averaged scores are added together and divided by six (6) for the final compulsory score.

2. Barrel section (Score 2):

Performance	X3
Artistic	X2
Consideration of Barrel & General Impression	X1

- Total is divided by six (6).

3. Final score:

- a) Scores 1 and 2 are added and divided by two (2) to produce the final score for the Event.

Article 510. Squad Event Scoring

1. Compulsory section for all Squad events:

Compulsory Score	75%
------------------	-----

Horse	25%
-------	-----

- The two (2) scores are totaled.
- The compulsory scores of the six (6) vaulters are added creating a single score for each of the compulsory exercises. If there is an alternate when the vaulters are declared for Freestyle, the 7th vaulter's scores are dropped. All averaged scores are added together and divided by the number of Compulsories, which changes by Squad classification, to create the final Compulsory score. In Recognized National Squad Event, the vaulters whose scores are included are those declared by the Squad coach to perform in the Freestyle. The score for the vaulter who does not perform in the Freestyle is dropped.

2. Freestyle section: 3* A Squad

Technique	50%
Artistic	25%
Horse	25%

- The three (3) Freestyle scores are totaled. This is the Squad's score for the Freestyle section.
- Freestyle section: 2* B Squad

Technique	50%
Artistic	25%
Horse	25%

- The three (3) Freestyle scores are totaled. This is the Squad's score for the Freestyle section.
- Freestyle section: 1* C Squad

Technique	50%
Artistic	25%
Horse	25%

- The three (3) Freestyle scores are totaled. This is the Squad's score for the Freestyle section.
- Freestyle section: 1* Trot Squad

Technique	X3
Artistic	X2
Horse	X1

- The three (3) Freestyle scores are totaled and divided by six (6). This is the Squad's score for the Freestyle section.
- Final score:
 - The Squad's Compulsory score and Freestyle score are added and divided by two (2). This is the Squad's final score for the event.

Article 511. Tie breakers.

- Individual 3* and 2* Young Vaulter/Gold Events:
 - Compulsory: Score for Basic Seat, Flag, etc. (3* Individual does not perform Basic Seat; therefore, the tie breaker begins with Flag). The Mount and Horse scores are not used.
 - Freestyle: Score for Artistic then Technique;
 - Technical Test: Score for Artistic, then Technique;
 - Overall: Compulsory score
- Individual 2* Silver, 1* Bronze, 1* Copper and 1* Trot Events:
 - Compulsory: Score for Basic Seat, Flag, etc. The Mount and Horse scores are not used.
 - Freestyle: Score for Artistic then Technique.
- Squad Event (3* A, 2* B, 1* C and 1* Trot)
 - Compulsory: Sum of the six (6) vaulters' scores for Basic Seat, then the sum for the Flag, etc. The mount and horse scores are not used.
 - Freestyle: Score for Artistic then score for Technique;
 - Overall: Compulsory score.
- Pas de Deux Event:
 - Freestyle: Score for Artistic, then score for Technique;
 - Overall: Score for Artistic, then score for Technique.
- Two Phase Squad Event (2* Canter, 1* Canter and 1* Trot):
 - Compulsory: Sum of the four (4) vaulters' scores for Basic Seat, then the sum for Flag, etc. The mount and horse scores are not used.

- b) Barrel: Score for Artistic and then score for Technique.
- 6. Ties that cannot be broken as stated, remain ties.
- 7. For all events with two (2) or more judges, each judge's scores shall be carried forward per the above.

CHAPTER VI. MEDALS

Article 601. General Rules. (See also Standing Rules, Section IX.)

- 1. Eligibility:
 - a) Only registered vaulters of the EVUSA and Individual Members in good standing may take medal exams.
 - b) Recreational Club members may take the Novice pin only.
 - c) All medal exam fees for each examinee must be paid prior to the start of the medal exam. Or be paid with the application for a medal using competition scores. No vaulter will be tested, or application processed, whose fees have not been received by the Medal Test Secretary or the examiner.
 - d) All medals may be earned using competition scores. Overall scores of compulsories and freestyle (if applicable) including horse scores are used, see Articles 604-607.
 - e) ~~Recreational Club members may take the Novice pin only.—~~
 - f) ~~All medal exam fees for each examinee must be paid prior to the start of the medal exam. No vaulter will be tested whose fee has not been received by the Medal Test Secretary or the examiner.~~
- 2. Examiner:
 - a) All medal exams must be given by an EVUSA Recognized Judge.
 - b) The Gold medal exam must be given by an EVUSA "R" Judge.
- 3. Format:

IN PERSON TESTING

- a) Exams may be taken in any order.
- b) Full requirements for each exam must be taken regardless of how many exams are taken in one (1) day.
- c) Only the medal for the exam that was applied for may be awarded. (For example, Novice pins may not be awarded in lieu of failed Trot exams).
- d) When exams are taken to the right, all Freestyle moves must also be performed to the right.
- e) Horses may be changed at the discretion of the examiner. If a horse misbehaves or is uneven and/or un-level, in bad condition, or shows signs of discomfort or fatigue the examiner may stop the exam.
- f) Horses and/or lungers may be substituted between Compulsories and Freestyle, but not at any other time.
- g) Scoring, penalties and deductions are the same as in competitive events. The maximum score of each exercise is 10. Decimals are allowed.
- h) A vaulter may have two (2) repeats to receive a passing or higher score. For all repeats a simple dismount (leg over neck to inside) is the proper dismount to use.
- i) If a vaulter passes an exam, the exam may not be retaken for a higher score. If a vaulter fails an exam, the exam may be retaken only once in the next 30-day period. An examination may be retaken the same day if the fees are paid there will be no late fee assessed.
- j) Compulsories are performed in the same format as in Individual Event.
- k) The Mount is not scored in the Novice, Trot, Copper and Bronze exam. Assisted Mounts are required for Novice and Trot exams, vaulters are required to mount unassisted for the Copper and Bronze exams, but it is not scored. The mount is scored for the Silver and Gold exam, but there is no minimum score requirement. ~~any medal exams. Assisted Mounts are required only for Trot and Novice exams.—~~

~~In 1* Bronze, 2* Silver and 3* Gold exams, not more than two (2) Freestyle exercises may be performed together without dismounting.~~

- l) Many freestyle exercises and their assigned Degree of Difficulty are listed in the current FEI Code of Points. If the exercise to be performed is not listed, contact the Medal Test Secretary for approval of the exercise.

COMPETITION SCORES SUBMITTED FOR MEDALS

- a) All medals may be earned with competition scores are limited to Trot, Copper, Bronze Silver and Gold. Overall scores using compulsories and freestyle (if applicable) including horse scores are used, see Articles 604-607
- b) Trot exams only need to submit overall compulsory scores there is not freestyle requirement.

- c) **THREE (3) overall scores earned at competition for medals must be by an EVUSA recognized Judge, earned at a Recognized EVUSA competition. Competition scores submitted for Gold medal must be from EVUSA 'R' Judges.**
- d) **The three (3) Competition scores MUST be within 18 months of applying for a medal.**

NOTE: Until the EVUSA Rulebook indicates otherwise, the EVUSA will allow Trot, Copper and Novice pin tests to be done virtually. Tests may be conducted as live video session, or may be pre-recorded. For pre-recorded sessions if a vaulter needs to use any of the repeats available a new video must be submitted with the repeated exercises. Tests must be conducted (if live) or submitted (if recorded), including any repeats, no more than 30 days after the indicated test date. If pre-recorded, the video must have been recorded within one year prior to the test date, and may be either recorded specifically for the medal test or may be video from a previous competition or event. All other rules for Medal Tests apply.

Article 602. Novice Award Requirements. ~~Performed at walk, trot or canter to the left or to the right.~~

1. ~~Novice pins may be taken to the left or to the right and at any of the gaits: walk, trot or canter. May be taken at three (3) gaits: Walk, trot and canter to the left and to the right.~~
2. The compulsory exercises to be performed are as in 1* Trot Individual (see Art. 423).
3. ~~An assisted~~The Mount is not scored ~~for Novice award. An assisted mount is required for the Novice award and may be given at any gait.~~ Vaulter ~~must then~~ performs the remaining six (6) compulsories with a minimum score of three (3) for each exercise.
4. Judged on:
 - a) ~~Correct mechanics: Half-Mill performed in the correct direction with attempted rhythm; Basic-Seat, Flag and Stand held four (4) strides with arms out—~~
 - b) Demonstrate awareness of safety
5. Two (2) repeats allowed as for other medal exams.
6. Spotters are allowed, but if the spotter assists the vaulter in any way, except for the Mount, the exercise will fail. Exercise may be repeated as in (5) above.
7. If the form is so bad as to affect the basic mechanics, the exercise will fail.
8. Award may **only be given once regardless of gait or direction and may** not be given commended or with honors.
9. Minimum passing score: 30%.
10. All other rules for medal exams apply.

Article 603. Trot Medal Requirements. ~~Performed at trot to the left or to the right.~~

1. Trot medal may be taken ~~in both directions~~to the left and/or to the right. .
2. The compulsory exercises to be performed are as in 1* Trot Individual Event. (See Article 423)
3. ~~The Mount is not scored for Trot exam and vaulters must receive a boosted mount.~~An assisted mount is required and not scored for the Trot medal. Vaulters ~~must~~performs the ~~remaining~~ six (6) ~~remaining~~ compulsory exercises.
4. The minimum score for all exercises is 5.0, except the minimum score for the Swing Forward is 4.5.
5. ~~The total score of all exercises must average 50%.No spotters allowed.~~
6. ~~No spotters allowed.~~Minimum overall score to pass for in person testing is 5.0.
7. ~~Minimum Passing Score: 50.00%~~Minimum overall score to pass for Competition Scores is 6.0.
8. Award may not be given commended or with honors.

Article 604. Copper Medal Requirements. ~~Performed at canter to the left or to the right.~~

1. Copper medal may be taken ~~to the left and/or to the right.in both directions.~~
2. The compulsory exercises to be performed are as in 1*Copper Individual Event. (See Article 420)
3. The Mount is not scored **but must be performed with no assistance for the Copper exam.** Vaulters must performs the ~~remaining~~ six (6) ~~remaining~~ compulsory exercises.
4. The minimum score for all exercises is 5.0, ~~except the minimum score for the Swing Forward is 4.5.~~
5. ~~The total score of all exercises must average 50%.No spotter allowed.~~
6. ~~No spotters allowed.~~Minimum overall score to pass for in person testing is 5.0.
7. ~~Minimum Passing Score: 50.00%~~Minimum score to pass for Competition Scores is 6.0.
8. Award may not be given commended or with honors.

Article 605. Bronze Medal Requirements. ~~Performed at canter to the left or to the right.~~

1. Bronze medal may be taken ~~to the left and/or to the right~~**in both directions.**
2. The compulsory exercises to be performed are as in 1* Bronze Individual Event (See Article 417).

3. The Mount is not scored **but must be performed with no assistance** for Bronze exam. Vaulters ~~must~~ performs the six (6) remaining compulsory exercises and any four (4) Freestyle exercises having an assigned Degree of Difficulty M or D. ~~(No Degree of Difficulty D's are allowed.)~~
4. **Freestyle exercises are to be performed in blocks of two (2) in the order specified on the medal exam sheet.**
5. The minimum score for all exercises is ~~55.0% with no exercise receiving less than a 5.5-6.0.~~
6. **The minimum overall score to pass in person or with competition scores:**
7. Final score:
 - Satisfactory: ~~60~~55.0% — 62.9%
 - Commended: 63.0% — 69.9%
 - With Honors: 70.0% — 100.0%

Article 606. Silver Medal Requirements. ~~Performed at canter to the left or to the right.~~

1. Silver medal may be taken to the left and/or to the right.
2. The compulsory exercises to be performed are as in 2* Silver Individual Event (See Article 414).
3. Vaulters perform the eight (8) compulsory exercises, and any six (6) Freestyle exercises having an assigned Degree of Difficulty R, D or M.
4. Freestyle exercises are to be performed in blocks of three (3) in the order specified on the medal exam sheet.
5. The total score of all exercises must average 65.0% with no exercise except the mount, receiving less than a 6.0.
6. Minimum overall score to pass in person or with competition scores:
 - Satisfactory: 65.0% — 69.9%
 - Commended: 70.0% — 79.9%
 - With Honors: 80.0% — 100.0%

Article 607. Gold Medal Requirements. ~~Performed at canter to the left or to the right.~~

1. Gold medal may be taken to the left and/or to the right.
2. The compulsory exercises to be performed are as in 3* Gold Individual Event (See Article 414)
3. Vaulters perform the nine (9) compulsory exercises, three (3) technical exercises from the current technical exercises posted in the FEI Rules for Vaulting and any eight (8) Freestyle exercises having an assigned Degree of Difficulty R or D.
4. Technical test exercises are to be performed in a block of three (3) and freestyle exercises are to be performed in blocks of four (4) in the order specified on the medal exam sheet. The total score of all exercises must average 75.%, with no exercise except the mount, scoring less than 7.0
5. the minimum overall score to pass in person or with competition scores:
 - Satisfactory: 75.0% — 80.0%
 - Commended: 80.1% — 84.9%
 - With Honors: 85.0% — 100.0%

CHAPTER VII. JUDGES

Article 701. Recognized Judges.

1. Recorded Judges “r”:
 - a) Recorded “r” Judges may judge all levels of medal exams except Gold.
 - b) Recorded “r” Judges may judge all levels of EVUSA recognized competitions and EVUSA only or unrecognized classes at USEF recognized competitions.
2. Registered Judges “R”:
 - a) Registered “R” Judges may judge all levels of medal exams.
 - b) Registered “R” Judges may judge all levels of EVUSA recognized competitions and USEF recognized competitions if they are licensed USEF Officials.

Article 702. Rules for EVUSA Recognized Judges.

1. Active status:
 - a) Recognized Judges must maintain Individual Membership in good standing throughout the calendar year.
 - b) Judges must attend the EVUSA Judges Forum each year and a minimum of one (1) additional training each year, and/or the equivalent as determined by the Technical Committee.
 - c) A judge may not have outstanding debts to the EVUSA.

2. Inactive status:
 - a) A judge who does not fulfill the above requirements will be placed on inactive status and may not judge until reinstated.
 - b) A notice will be sent to the judge placed on inactive status.
 - c) A judge placed on inactive status may be required to take a written test before reinstatement.
 - d) The judge may be reinstated upon fulfillment of the above requirements.

Article 703. Promotion to EVUSA Recorded Judge “r”.

1. Apprentice must attend a minimum of eight (8) judges general training sessions, two (2) of which must be EVUSA Judges Forums. In addition, special training sessions may be assigned to any or all applicants depending on experience. Apprentice must clerk or time with a Recognized Judge for all types of recognized events. This requires the apprentice to sit with a minimum of three (3) different EVUSA “R” Judges. Applicant is responsible for maintaining and submitting a record of the clerking hours to the Technical Committee Chair.
2. Apprentice must have clerked for a minimum of one (1) medal exam.
3. Apprentice must pass a written and/or practical exam.
4. A fee is required for promotion to Recorded Judge “r”.

Article 704. Certification as an EVUSA Registered Judge “R”.

1. Applicant must attend a minimum of eight (8) judges general training sessions, after their promotion to Recorded “r” status, two (2) of which must be EVUSA Judges Forums. In addition, special training sessions may be assigned depending on experience.
2. Applicant must have judged a minimum of six (6) EVUSA Recognized Competitions, four (4) of which they must have served as President of the Ground Jury* for the entire competition.
3. Applicant must have shadow judged a minimum of two (2) USEF Recognized Competitions, one (1) of which must be a National Championship or East/West Festival with different EVUSA “R” judges who are also members of the Technical Committee, for a total of fourteen (14) hours or two (2) full days of competition. Shadow judging entails sitting in a separate judge area with a scribe and scoring all aspects during the day. Discussion should be had with the mentoring judge promptly at appropriate breaks to clarify questions and compare scores and comments.
4. Advancement to Registered Judge “R” requires approval of the EVUSA Technical Committee.
5. Applicant must pass a written and or practical exam.
6. A fee is required on promotion to Registered “R”.
7. Upon completion of the EVUSA process for “R”, judge may apply to the USEF to become a USEF “R”.

*President of the Ground Jury (PoGJ) - The judge who is primarily responsible for interacting with Competition Management, creating the judge’s rotation (if multiple judges) and being the “go-to” contact for any rule clarifications prior to and during the competition. If only one judge is hired, then that judge is the PoGJ.

Article 705. Apprentice Judge Program.

1. Eligibility:
 - a) Applicant must be at least eighteen (18) years of age.
 - b) Applicant must have been an active Individual Member, in good standing for at least two (2) years.
 - c) Applicant must have attended at least one (1) East/West Coast Festival or National Championships as a competitor or volunteer, and one (1) designated Open Judges Forum, prior to application. Technical Committee shall make every attempt to offer an Open Judges Forum at the Education Symposium or via Zoom each year. Applicant must have at least the following experience:
 - 16 hours of clerking/timing with a “R” judge, each just must sign off on hours.
2. Application:
 - a) Applicants must submit a completed application form to the Chairman of the Technical Committee along with the required application fee of \$100.00. This application must be on the official form and may be submitted by email, post or hand delivery.
 - b) The following information is required of the applicants:
 - i. Opinion of a judge’s responsibilities
 - ii. Reason for wanting to be a judge:
 - Basic experience as a vaulter, coach or instructor, worker/administrator at competitions/ Fests/medal exams/meetings (committee work)
 - Judging experience in any other field
 - iii. Names and addresses of three (3) EVUSA Registered “R” judges, one (1) character reference and one (1) EVUSA Individual member who is not affiliated with the applicant’s club (if any).

- iv. If Candidate is unknown to any EVUSA Registered “R” judge (for reasons such as residence in an inactive region), their application will be given special consideration by the screening panel.
3. Procedure:
 - a) Applications will be accepted anytime during the calendar year.
 - b) The Technical Committee will review applications when received. Applicants will be notified of the decision by the Technical Committee within sixty (60) days of receipt.
 - c) Applicant then must pass a proctored written exam, with a minimum score of 70%, prior to attending any official judge’s training.
 - d) Applicants who are not accepted into the program may reapply the following year.
 4. Rules for Apprentice Judges:
 - a) Apprentices must maintain Individual Membership in good standing throughout the calendar year, failure to do so will result in dismissal from the Apprentice program. A member in good standing is one who has paid current EVUSA dues by February 1 and has no outstanding debts to the EVUSA.
 - b) Continue to scribe and sit with licensed judges
 - c) Must attend training sessions
 - d) May not judge any medal exams
 - e) May not judge recognized national events, except at non recognized competitions.

CHAPTER VIII. PROTESTS AND GRIEVANCES

Article 801. Protests.

1. Rules:
 - a) May be concerned only with infractions of the rules as published in the EVUSA Rule Book
 - b) May not be made against the judge’s scoring or judging
 - The judge’s decision, representing their individual preference, is final.
 - c) May be submitted only by members of the EVUSA in good standing
 - If the protesting party is other than a Squad coach, and is affiliated with a Squad, the protest must be co-signed by the coach of that Squad.
 - d) The protest must be submitted prior to the close of the competition.
2. Procedures:
 - a) Must be submitted on an official EVUSA Protest form, available from the show manager
 - b) Must be completely filled out, signed and returned to the show manager in a sealed envelope
 - c) Must be accompanied by a fee, refundable only if the protest is upheld
 - d) The protest will be submitted (sealed) to the President of the Ground Jury.
 - e) The Ground Jury shall make an on-the-spot ruling. In the absence of a Ground Jury, the Judge at A may, in their best judgment, do one (1) of the following:
 - Make an on-the-spot ruling
 - Refer the protest to the Technical Committee within seventy- two (72) hours for a ruling
 - f) On-the-spot decisions by the Ground Jury or the Judge at A are final and may not be protested.
 - g) On-the-spot decisions will not be negated by later rules; however, these decisions do not establish a precedent for later rulings.
 - h) The decision of the Ground Jury or Judge at A will be recorded on the EVUSA Official Protest form, signed and the show manager will be notified of the decision.
 - i) All protests will be mailed by the President of the Ground Jury to the Chairman of the EVUSA Technical Committee.
 - j) The protesting party will be notified of the decision.
 - k) All protests will be kept on file.

Article 802. Grievances.

1. Rules:
 - a) May be concerned only with a complaint which is not governed by a rule
 - b) May be submitted only by a Individual Member of the EVUSA in good standing
 - c) May pertain only to incidents which occur during an EVUSA activity
 - d) May not be made against the judge’s scoring or judging
 - The judge’s decision, representing their individual preference, is final.
2. Procedures:
 - a) Must be submitted on an official EVUSA Grievance form, available from the Show Manager

- b) Must be completely filled out, signed, and filed with the President of the EVUSA within seventy-two (72) hours of the alleged incident
- c) Must be accompanied by the required fee; half of which will be refunded if the grievance is upheld
- d) Within fifteen (15) days of the receipt of the official grievance, the President shall:
 - Notify, in writing, the parties accused in the alleged incident
 - Submit the grievance to the Chairman of Grievance Committee for investigation
- e) The Grievance Committee shall have prepared within sixty (60) days or by the next Board of Directors meeting, whichever comes first, a written review of the alleged incident which shall include:
 - Signed statements of witnesses
 - Any written documentation
 - All facts garnered
- f) The written review, including all statements and documents, and the recommendation of the Grievance Committee, shall be submitted to the President of the EVUSA for presentation to the Board of Directors for a decision.
- g) The parties accused of the alleged incident shall be notified in writing at least thirty (30) days prior to the Board of Directors meeting that the Board will be reviewing the matter of the Grievance in a closed session, and that they may be present and be heard by the Board during the Board's review. The parties accused may also submit a written statement to the Board via the President of the EVUSA, if they so choose.
- h) If the grievance lacks sufficient merit, or the Grievance Committee is unable to garner sufficient supporting evidence, the Board may move to dismiss the allegation and take no action.
- i) The accused parties and the parties filing the grievance shall receive written notification of the decision of the Board within ten (10) days after the Board of Directors meeting.
- j) The matter of the grievance and the decision of the Board may be published in Equestrian Vaulting Magazine within ninety (90) days.
- k) All written documents, statements, reports of the Grievance Committee, and the decision of the Board of Directors shall remain on file with the President of the EVUSA and shall be kept confidential.

CHAPTER IX. AMENDMENTS TO THE RULE BOOK

Article 901. Procedures.

1. Any registered member of the EVUSA in good standing may submit recommendations for amendments to the EVUSA Rule Book to the Chairman of the Technical Committee.
2. All recommendations must be submitted in writing and include the following information:
 - a) Page and section(s) to be amended
 - b) Specific reason for the requested amendment, including examples if possible
 - c) Suggestions for proposed wording
3. All recommendations will be reviewed by the Technical Committee.
4. Action taken by the Technical Committee to amend the EVUSA Rule Book will be submitted to the Board of Directors for review and approval.
5. All rule changes will be published in Equestrian Vaulting Magazine and/or the EVUSA Blast and will become effective on the date specified.
6. Rule change proposals are reviewed throughout the year by the Technical Committee and presented annually to the Board to take effect for the next competition year.

GUIDELINES

The following guidelines are for unrecognized events and classes. Competition management may alter these Guidelines to meet local or regional needs and interests. The intention is to standardize unrecognized classes between the EVUSA regions. Any offered classes that are modified should be identified as a modified class in the prize list. For a template prize list on how to judge these classes, please go to <https://equestrianvaulting.org/forms/>

Unrecognized classes that are offered at EVUSA Recognized Competitions, during the recognized competition hours, must adhere to certain EVUSA Rules (see Standing Rules, Section VIII.F.1). Unless otherwise specified, all applicable rules (including Horse Use), deductions and penalties from the rules for EVUSA National Recognized Events apply. Unrecognized Masters divisions may be offered for all EVUSA classes for vaulters over the age of 18.

Work on the Barrel is considered to be preparation for work on the Horse and all barrel classes should follow the rules of the corresponding horse event, unless specified differently in the Prize List. Prize list must state what is allowed/disallowed and the specific deductions that apply if not performed as stated.

CHAPTER X. GENERAL, ELIGIBILITY AND AWARDS

Article 1001. General.

1. Assisted Mounts:
 - Required for all unrecognized horse classes and may be given at any gait, including standing still.
 - Not required for Barrel but allowed.
2. Competition is to the left or the right for all Appendix B and C classes.
3. The Horse score is the same as Trot events, regardless of gait for all Appendix B and C classes.
4. Masters Classes may be offered for all equivalent EVUSA Recognized and Unrecognized classes. All vaulters competing in the Masters Class Divisions must be at least 18 years of age.
 - a. All Masters classes are unrecognized.
 - b. Masters vaulters will be judged using the same rules as the equivalent class.

Article 1002. Eligibility and Awards.

1. At EVUSA Recognized Competitions, vaulters, coaches and lungers must be registered members of the EVUSA in good standing or must pay Non-Member fee.
2. All Appendix classes must be judged by an EVUSA Recognized judge in order for scores to count towards any EVUSA or Regional Awards.

APPENDIX A – BARREL CLASSES

CHAPTER XI. INDIVIDUAL BARREL EVENTS

Article 1101. Individual Barrel

1. Divided into Advanced, Intermediate and Novice.
 - a. Advanced – Any 2* Canter and above vaulter.
 - b. Intermediate - Any 1* Canter vaulter.
 - c. Novice - Any 1* Trot or unrated vaulter.
2. Consists of one (1) round of Freestyle.
3. May be divided into Men's and Women's divisions.

Article 1102. Freestyle

1. Freestyle is a one (1) minute (maximum) routine of static and dynamic exercises.
2. Advanced and Intermediate have no restrictions on exercises performed.
3. Novice has the same restrictions as Recognized 1* Trot classes.
4. May be divided into Men's and Women's divisions.

Article 1103. Individual Barrel Freestyle

1. Judged on:

Technique	X3
Artistic	X2
Consideration of Barrel & General Impression	X1

2. Falls:
 - a. The vaulter may continue after a fall. They must remount within one (1) minute.
 - b. Unsuccessful exercises may be repeated.
3. See EVUSA Rules, Chapter V, Scoring, for penalties and deductions.

CHAPTER XII. PAS DE DEUX AND SQUAD BARREL EVENTS

Article 1201. Pas de Deux and Squad Barrel

1. Divided into Advanced, Intermediate and Novice.
 - a. Advanced—Any combination of Canter vaulters.
 - b. Intermediate – Any combination of Trot and Canter vaulters.
 - c. Novice - Any Combination of Trot and unrated vaulters.
2. Consists of one (1) round of Freestyle.
3. Squads may consist of 3 – 7 vaulters.

Article 1202. Freestyle

1. For Pas De Deux freestyle is a ninety (90) second (maximum) routine of static and dynamic exercises.
2. For Squad freestyle time depends on the number of vaulters, thirty (30) seconds is allocated for each member to a maximum of two and a half (2.5) minute routine of static and dynamic exercises.
3. There are no restrictions on exercises performed at any level for Pas de Deux or Squad.

Article 1203. Pas de Deux and Squad Barrel Freestyle

1. Judged on:

Technique	X3
Artistic	X2
Consideration of Barrel & General Impression	X1

2. Falls:
 - a. The vaulter(s) may continue after a fall. They must remount within one (1) minute.

- b. Unsuccessful exercises may be repeated.
- 3. See EVUSA Rules, Chapter V, Scoring, for penalties and deductions.

APPENDIX B – PRELIMINARY 1* HORSE EVENTS

CHAPTER XIII. 1* PRELIMINARY INDIVIDUAL - HORSE

Article 1301. Individual Preliminary Horse

- 1. This class may be offered at all gaits.
- 2. Open to vaulters who are not competing in any other recognized classes at that gait.
- 3. Consists of one (1) round each of 1* Compulsories and Freestyle.
- 4. Vaulters must receive a boosted mount for both Compulsories and Freestyle, the boost may be performed at any gait, including the standstill.
- 5. May be divided into Men's and Women's divisions.

Article 1302. Compulsories

- 1. Performed as in 1* Individual Trot
 - 1) Boosted Vault On (Not scored)
 - 2) Basic Seat
 - 3) Flag
 - 4) Stand
 - 5) Swing Forward
 - 6) 1/2 Mill
 - 7) Swing Backward, followed by dismount to inside
- 2. Judged on:
 - a. Performance
 - b. Horse
- 3. Falls:
 - a. The vaulter may continue after a fall. They must remount within one (1) minute.
 - b. The unsuccessful exercise may not be repeated.

Article 1303. Freestyle

- 1. Freestyle is a one (1) minute (maximum) routine of static and dynamic exercises.
 - a. Vaulter must stay in contact with horse. Ground jumps and leaps above the horse are NOT allowed (including hopping from knees to feet in any direction).
 - Two (2) points are deducted from Artistic for performing
 - b. Only E dismounts that land facing forward are allowed.
 - One (1) point is deducted from Artistic for performing

Article 1304. Individual Preliminary Horse Freestyle

- 1. Judged on:

Technique	X3
Artistic	X2
Horse	X1

- 2. Falls:
 - a. The vaulter may continue after a fall. They must remount within one (1) minute.
 - b. The unsuccessful exercise may be repeated.
- 3. See EVUSA Rules, Chapter V, Scoring, for penalties and deductions.

CHAPTER XIV. 1* PRELIMINARY PAS DE DEUX AND SQUAD - HORSE

Article 1401. Pas de Deux and Squad Preliminary Horse

- 1. This class may be offered at all gaits.
- 2. Open to vaulters who are not competing in any other recognized Pas de Deux or Squad classes at that gait.
- 3. Consists of one (1) round each of 1* Compulsories and Freestyle.
- 4. Squads may consist of 3 – 7 vaulters.

Article 1402. Compulsories

1. Squad time limit: One (1) minute per vaulter is allocated up to a maximum of seven (7) minutes.
2. Performed as in 1* C Squad, except for the boosted mount. Vaulters should follow one another immediately, there is no deduction for subsequent vaulters entering the circle while a previous vaulter is performing compulsories:
 - 1) Boosted Vault On (Not scored)
 - 2) Basic Seat
 - 3) Flag
 - 4) Stand
 - 5) Swing Forward
 - 6) 1/2 Mill
 - 7) Swing Backward, followed by dismount to inside
3. Judged on:
 - a. Performance
 - b. Horse
4. Falls:
 - a. The vaulter may continue after a fall. They must remount within one (1) minute.
 - b. The unsuccessful exercise may not be repeated.

Article 1403. Freestyle

1. For Pas De Deux freestyle is a ninety (90) second (maximum) routine of static and dynamic exercises.
2. For Squad freestyle time depends on the number of vaulters, thirty (30) seconds is allocated for each member to a maximum of two and a half (2.5) minute routine of static and dynamic exercises.
 - a. Only single and double exercises with a Degree of Difficulty of M or less are allowed, no triples.
 - b. Only E dismounts that land facing forward are allowed.
 - One (1) point is deducted from Artistic for performing triples, D rated exercises or non E Dismounts.

Article 1404. Pas de Deux and Squad Horse Freestyle

1. Judged on:

Technique	X3
Artistic	X2
Horse	X1

2. Falls:
 - a. The vaulter(s) may continue after a fall. They must remount within one (1) minute.
 - b. Unsuccessful exercises may be repeated.
3. See EVUSA Rules, Chapter V, Scoring, for penalties and deductions.

APPENDIX C - D HORSE EVENTS

CHAPTER XV. D INDIVIDUAL – HORSE

Article 1501. Individual

1. This class may be offered at any gait.
2. Open to non-medaled vaulter; Novice pin holders allowed.
3. Consists of one (1) round each of D Compulsories and Freestyle.
4. Spotters and assistance are allowed.
5. May be divided into Men's and Women's divisions.

Article 1502. Compulsories

1. D-Level Compulsories:
 - 1) Boosted Vault On (not scored)

- 2) Modified Basic Seat
 - 3) Box
 - 4) ~~Quarter Mill with Inside Side Seat~~ Kneel
 - 5) ~~Quarter Mill with Outside Side Seat~~ Forward Plank
 - 6) ~~Swing to Plank~~ Quarter Mill
 - 7) ~~Modified Kneel, Scissor Down to Reverse Seat~~ Inside Seat
 - 8) ~~Swing to Reverse Plank with Quarter Mill~~ Dismount to Inside One leg Bench, Quarter Mill Dismount to the Inside
2. Judged on:
 - a. Performance
 - b. Horse
 3. Falls:
 - a. The vaulter may continue after a fall. They must remount within one (1) minute.
 - b. The unsuccessful exercises may not be repeated.

Article 1503. Freestyle

1. Freestyle is a one (1) minute (maximum) routine of static and dynamic exercises.
 - a. Vaulter must stay in contact with horse. Only M and E exercises are allowed, including any of the D Compulsories. Ground jumps and leaps above the horse are NOT allowed (including hopping from knees to feet).
 - Two (2) points are deducted from Artistic for performing
 - b. Only E dismounts that land facing forward are allowed.
 - One (1) point is deducted from Artistic for performing.

Article 1504. Individual D Freestyle

1. Judged on:

Technique	X3
Artistic	X2
Horse	X1
2. Falls:
 - a. The vaulter may continue after a fall. They must remount within one (1) minute.
 - b. Unsuccessful exercises may be repeated.
3. See EVUSA Rules, Chapter V, Scoring, for penalties and deductions.

CHAPTER XVI. D PAS DE DEUX AND SQUAD – HORSE

Article 1601. Pas de Deux and Squad

1. These classes may be offered at any gait.
2. Open to non-medaled vaulter; Novice pin holders allowed.
3. Consist of one (1) round each of D Compulsories and Freestyle.
4. Squads may consist of 3 – 7 vaulters.

Article 1602. Compulsories

1. Squad time limit: One (1) minute per vaulter is allocated up to a maximum of seven (7) minutes.
2. D-Level Compulsories, performed as in 1* Trot Squad. Vaulters should follow one another immediately, there is no deduction for subsequent vaulters entering the circle while a previous vaulter is performing compulsories:
 - 1) ~~Modified Basic Seat~~ Boosted Vault On (not scored)
 - 2) ~~Modified Basic Seat~~ Box
 - 3) ~~Quarter Mill with Inside Side Seat~~ Box
 - 4) ~~Quarter Mill with Outside Side Seat~~ Kneel
 - 5) ~~Swing to Plank~~ Forward Plank
 - 6) ~~Modified Kneel, Scissor Down to Reverse Seat~~ Quarter Mill
 - 7) ~~Swing to Reverse Plank with Quarter Mill~~ Dismount to Inside Inside Seat
 - 8) ~~Reverse One Leg Bench, Quarter Mill~~ Dismount to the Inside
3. Judged on:
 - a. Performance
 - b. Horse

4. Falls:
 - a. The vaulter may continue after a fall. They must remount within one (1) minute.
 - b. The unsuccessful exercises may not be repeated.

Article 1603. Freestyle

1. For Pas De Deux freestyle is a ninety (90) second (maximum) routine of static and dynamic exercises.
 - a. Only single and double exercises with a Degree of Difficulty of M or less are allowed.
 - b. Only E dismounts that land facing forward are allowed.
 - One (1) point is deducted from Artistic for performing triples, D rated exercise or non E Dismounts.
2. For Squad freestyle time depends on the number of vaulters, thirty (30) seconds is allocated for each member to a maximum of two and a half (2.5) minute routine of static and dynamic exercise.
 - a. Only single and double exercises with a Degree of Difficulty of M or less are allowed, no triples.
 - b. Only E dismounts that land facing forward are allowed.
 - One (1) point is deducted from Artistic for performing triples, D rated exercise or non E Dismounts.

Article 1604. Pas de Deux and Squad Freestyle

1. Judged on:

Technique	X3
Artistic	X2
Horse	X1

2. Falls:
 - a. The vaulter may continue after a fall. They must remount within one (1) minute.
 - b. Unsuccessful exercises may be repeated.
3. See EVUSA Rules, Chapter V, Scoring, for penalties and deductions.

CHAPTER XVII. DESCRIPTION OF D COMPULSORIES

MODIFIED BASIC SEAT

Essence:

- **Harmony, balance, seat and posture**

~~The vaulter sits astride, erect, and centered directly behind the surcingle, with legs down and in contact with the horse, forming a straight vertical line through the ear, shoulder, hip, and heel. The arms are extended and stretched forward with the tips of the fingers at eye level, keeping shoulders back (good posture). The vaulter should establish a seat, where two-thirds of the weight is distributed equally on the two seat bones and one-third is distributed down the legs.—~~

The vaulter sits astride, erect, and centered directly behind the surcingle, with legs down and in contact with the horse, forming a straight vertical line through the head, shoulder, hip, and heel. The vaulter establishes a three-point seat, where 2/3 of the weight is distributed equally on the two sitting bones and 1/3 on the thighs. The arms stretched and extended forward with the tips of the fingers at eye level, keeping shoulders back to maintain correct posture. The Modified Basic Seat is held for four (4) full strides.

Basic Scoring:

- ~~Score of 10—Three-point seat with torso upright, legs down and in contact with the horse, forming a straight vertical line through the ears, shoulders, hip and heel and following the horse's movement perfectly. Arms out front, fingers at eye level.—~~
- ~~Score of 6—Three-point seat with torso upright but with slight posture issues. The horse's movement is absorbed satisfactory.—~~
- ~~Score of 5—Extreme legs forward or “Chair Seat”—~~
- ~~Score of 4—Extreme arched back and no weight on seat bones. Bracing of legs to keep from falling forward (Remember arms are forward). Classic forked seat.~~
- Score of 10 - Correct posture, balance, absorption, and leg position.
- Score of 8 – Correct posture, balance, and absorption. Minor deviations in the leg position.
- Score of 6 – Medium deviations in posture, balance, and/or leg position. There is a lack of absorption causing the seat to come off the horse once.
- Score of 5 - Legs forward while leaning back (“Chair Seat”)

- Score of 4 - Arched back, seat lifting off the horse, legs bracing to prevent vaulter from falling forward ("Fork Seat"). Seat lifting off the horse more than once.

Deductions –

- -2 Points: ~~Wrong arm position in basic seat, side seats and kneel~~ Incorrect arm position

BOX

Essence: Harmony and balance

- Establishing good base of support for flag ~~Harmony and Balance~~

~~From seat astride, the vaulter swings into box, with both legs simultaneously, landing first on the tops of the ankle and slowly lowering to the shin and knees. Legs are on either side of the horse's spine with weight distributed evenly. Toes are pointed and conforming to the horse's back. Shoulders are directly over the hands and at the same height as the hips, with the elbows close to the torso. Hips are nearly at a 90-degree angle from the torso to the upper leg and are directly above or slightly behind the knees. Head remains up facing forward.—~~

From seat astride, the vaulter swings into box, with both legs simultaneously, landing first on the tops of the ankle and lowering controlled to the shin and knees. Legs are on either side of the horse's spine with weight distributed evenly. Toes are pointed and conforming to the horse's back. Shoulders are directly over the hands and at the same height as the hips, with the elbows close to the torso. Hips are nearly at a 90-degree angle from the torso to the upper leg and are directly above or slightly behind the knees. The movement of the horse is absorbed by the vaulter's supporting arms (shoulders, elbows and wrists), as well as both legs (knees and hips). Head remains up facing forward with the chin higher than the shoulders. The Box is held for four (4) full strides.

Basic Scoring:

- ~~Score of 10—Vaulter swings upward, landing softly into box. Lower legs are completely against the pad and horse. Shoulders are at same level as hips and back is straight. Elbows are tucked in and head is lifted.—~~
- ~~Score of 8—Shoulders are slightly higher than hips but back is still straight.—~~
- ~~Score of 6—Shoulders clearly higher than hips with slight arching or rounding of the back. Some air under lower leg.—~~
- ~~Score of 4—Shoulders well above hips. Arched back with lower legs off the horse. Elbows turned outward.—~~
- Score of 10 - Correct swing, absorption, balance, alignment, and posture.
- Score of 8 – Correct absorption, balance, and posture. Minor deviation of alignment with Shoulders slightly higher than hips.
- Score of 6 – Medium deviations in absorption such as lacking contact with the lower leg and/or arm stiffness. Medium deviation in posture (arched or rounded back). Shoulders higher than hips.
- Score of 4 – Major deviations of absorption (arms straight and/or bracing), balance, alignment and/or posture (arched or rounded back, elbows outward).

Deductions –

- Up to -2 Points: For little to no swing into Box, ~~Swing to Forward Plank and Reverse Plank~~

~~QUARTER MILL TO INSIDE SIDE SEAT~~ KNEEL

Essence: Harmony, balance and security

- Harmony, balance, ~~seat and posture~~ and security

~~From seat astride the vaulter makes a leg pass to the inside with the right leg completely stretched. The leg is carried over the horse in a high, wide arc (like a semi-circle), each handle is released and retaken in turn as the leg passes.— The mill ends in inside seat with legs together and in contact with the horse. The upper body stays erect and centered. Head and body rotate with each pass of the leg. Both hip bones stay in contact with pad during— entire exercise. There are no timing faults for the leg pass in the quarter mill.—~~

The vaulter sits in an inside side seat with arm out for four (4) strides. The vaulter is facing at a right angle to the horse's shoulder axis. The right hand is moved to the inside grip. The left hand is extended out laterally with the tips of the fingers level with eyes.—

The right leg is carried back over the horse's neck at a controlled pace. Leg stretches softly down to wrap. The exercise is completed with the vaulter sit—ting forward in seat astride.—

From the box position, the vaulter slides the knees forward and directly under the hips with the lower legs parallel to the horse's spine. The vaulter's weight remains evenly distributed along the lower legs, toes are pointed and conforming to the horse's back. The arms stretched and extended forward with the tips of the fingers at eye level, keeping shoulders back to maintain correct posture. The hips press forward into a kneeling position, forming a straight vertical line through the head, shoulders, hips, and knees. The Modified Kneel is held for four (4) full strides.

Basic Scoring:

- ~~Score of 10—Leg is fully stretched and at or above 45 degrees as it passes over handles. Torso is nearly vertical with good posture. Vaulter maintains posture in inside side seat with arm out (and inside handle is being held). Legs are against horse and together.—~~

- Score of 8—Leg is slightly less than 45 degrees but is still stretched. Good form and posture are maintained throughout. Form is good in the side seat. Score of 6—Slight loss of form and posture during leg pass and side seat. Legs slightly apart but still against horse. Satisfactory harmony in seat.—
- Score of 4—Poor form or posture. Elevation of leg is very low. Not able to properly sit in the side seat with arm out (lacking harmony in the side seat)
- Score of 10 - Kneeling directly behind surcingle with lower legs flat, knees and feet slightly apart. Correct posture with hands at eye level.
- Score of 8 – Correct posture with hands at eye level. Slight separation of knees. Slight break in line at hips.
- Score of 6 - Clear separation of knees. Arms too high or low. Medium deviation in posture. Minor hip flexion.
- Score of 4 - Hips flexed around 90 degrees. Lower legs coming off the pad. Major deviation in posture. Loss of balance.

Deductions –

- -1 Point: Holding wrong handle in side seats
- -2 Points: Wrong arm position in basic seat, side seats and kneel Incorrect arm position
- -2 Points: Touching pad behind the horse in Quarter Mill

QUARTER MILL TO OUTSIDE SIDE SEAT FORWARD PLANK

Same as above; except the left leg is carried over the horse's neck to the outside and ending with the vaulter sitting in a sideways seat facing outside. The left hand moves to the outside handle and the right hand is extended laterally. Finally, the left leg is carried back over the horse's neck, landing back in forward seat astride.—
Base scoring and deductions the same as Mill to the Inside Side Seat—

SWING TO FORWARD PLANK

Essence: Harmony, strength and control

- Initiating swing, core strength and control Harmony, strength and control

Stretching both legs forward, the vaulter swings through an arc in an upward direction. The upper body remains upright and the legs remain straight throughout the movement. Vaulter hovers momentarily above the horse before landing softly in plank with the tops of the feet together on the horse's croup and shoulders in front of or directly above the hands. Body forms a stretched line from the top of the head to the hips and from the hips to the heels with a flat back. Legs are together and on either side of the horse's spine. The shoulders are in front of the handles with the arms straight. The vaulter's weight is mostly in the arms with the remainder on the stretched foot and ankle.—
After four strides, the vaulter bends the knees to begin modified kneel.—

From the Modified Kneel, the vaulter softly places one foot then the other (either foot may be placed first) on the croup to stretch into the Forward Plank. Feet and ankles are stretched so that the tops of the feet are flat on the croup. Shoulders are slightly in front of or directly over the hands, arms straight. Body forms a stretched line from the top of the head, shoulders, hips, and heels, while maintaining correct posture. Legs are together and on either side of the horse's spine. The vaulter's weight is mostly in the arms with the remainder on the stretched foot and ankle. The Forward Plank is held for four (4) full strides.

Basic Scoring:

- Score of 10—Vaulter holds the stretched and slightly curved hollow body position without losing tension (sagging in middle). Arms remain straight and shoulders stay in front of handles. Legs are held together throughout exercise.—
- Score of 8—A brief loss of core tension during the exercise.—
- Score of 6—The slightly curved line is broken at the hips (slight arched back or flexed hip) but held steady. Legs slightly apart.—
- Score of 4—An extreme break in the back/hips or loss of core tension. Legs apart and/or knees bending.—

Deductions—

- Up to -2 Points: For little to no swing into Box, Swing to Forward Plank and Reverse Plank
- Score of 10 – Correct posture and maintenance of body tension throughout the entire exercise. Arms are straight and shoulders are directly over or slightly in front of the handles. Legs remain together throughout the exercise.
- Score of 8 – Minor deviation of posture or body tension during the exercise. Arms are straight, shoulders may be directly over, slightly in front, or slightly behind the handles. Legs remain together throughout the exercise.
- Score of 6 – Medium deviation of posture (arched back or piked hip) or body tension during the exercise. Arms are straight, shoulders may be directly over, slightly in front, or slightly behind the handles. Legs slightly apart during the exercise.
- Score of 4 – Major deviation of posture (arched back or piked hip) and/or loss of body tension. Arms bent. Legs apart and/or loss of form in legs (knees bent, flexed feet). Collapse.

MODIFIED KNEEL, SCISSOR DOWN TO REVERSE SEAT/QUARTER MILL

Essence: Harmony, seat and posture

- Balance, security and control Harmony, seat and posture

The vaulter slides the knees forward and directly under the hips with the lower legs angled slightly outward. The vaulter's weight remains evenly distributed along the lower legs. Upon releasing handles the arms are extended and stretched forward with the tips of the fingers at eye level. The hips press forward into a kneeling position, forming a straight line between the head, shoulders, hips, and knees.—

After four strides, the vaulter takes the grips with both hands simultaneously, then shifts weight forward and over the hands. Vaulter straightens legs, lifting hips into the air momentarily, then crosses the outside leg in front of the inside leg, turning the hips to the inside, and slides down to reverse seat. Vaulter maintains in controlled contact with horse from the ankles through the knees and seat.—

From plank vaulter sits softly into seat astride and makes a leg pass to the inside by stretching and straightening the outside leg to turn towards the lungers with the right leg completely stretched. The leg is carried over the horse's neck in a high, wide arc (like a semi-circle), each handle is released and retaken in turn as the leg passes. The vaulter remains in a correct, balanced sitting position to the inside while maintaining a vertical line from head, shoulder, hip, and heel of the resting leg. The head and body rotate with the pass of the leg. Both hip bones stay in contact with the pad during entire exercise. There are no timing faults for the leg pass in the quarter mill but should be accomplished within 4 strides.

Basic Scoring:

- Score of 10—Kneeling directly behind sure-ingle with lower legs flat, knees together and feet slightly apart. Straight line from ear to shoulder to hip and to knee. Excellent posture with hands at eye level.—
- Score of 8—Slight separation of knees. Slight break in line at hips.—
- Score of 6—Clear separation of knees. Arms too high or low. Some weakness in posture. Some flexion of hips.—
- Score of 4—Hips flexed around 90 degrees. Lower legs coming off the pad. More than 90 degrees of hip flexion and posture issues. Loss of form.—
- Score of 10 - Leg is fully stretched and at or above 45 degrees as it passes over handles. Torso is nearly vertical with correct posture.
- Score of 8 - Leg is slightly less than 45 degrees but is still stretched. Torso is nearly vertical with correct posture.
- Score of 6 – Medium deviation in posture (leaning back and/or rounded back). Leg is less than 45 degrees. Minor loss of form of the stretched leg.
- Score of 4 – Major deviation in posture (leaning back and/or rounded back). Leg pass does not clear the handle(s). Seat comes off horse during the leg pass.

Deductions –

- -2 Points: Wrong arm position in basic seat, side seats and kneel—
- -2 Points: Turning wrong way in Scissors down from Kneel/Touching pad behind the horse in Quarter Mill

REVERSE PLANK WITH QUARTER MILL DISMOUNT TO INSIDE/INSIDE SEAT

Essence: Harmony, balance and posture

- Initiating swing, core strength and control Harmony, balance and posture

Beginning in a reverse seat with hands on top of the handles, the vaulter pushes into an arched position with the shoulders reaching up and away from the sure-ingle. The vaulter swings the legs toward the croup with the shoulders traveling past the sure-ingle toward the horse's neck. The vaulter swings with a hollow body and lands softly into Reverse Plank with the feet together. Facing upward, the body forms a stretched line from the top of the head through the hips and ankles. With hands on top of the handles, the vaulter's arms are stretched with the shoulders above or slightly behind the handles. Legs are together with feet on either side of the horse's spine. The head is the extension of the longitudinal body axis. After four strides, the vaulter slides down to reverse seat, keeping the hips elevated until the body is vertical directly behind the sure-ingle. From seat rear ways, the vaulter performs a reverse quarter upper right leg and with closed legs and stretched hips, the vaulter pushes against the handles upwards and away from the horse. The handles are released and the vaulter lands with legs hip width apart, hips and shoulders parallel to the horse's shoulders. The upper body slightly bent forward in the absorption phase of the landing and continues in a controlled run in the same direction as the horse.—

The upper body stays erect and centered. The vaulter is facing at a right angle to the horse's shoulder axis. The legs are together and wrapped softly against the horse's side. The forward hand is moved to the inside grip. The opposite hand is extended out laterally to point over the horse's tail, with the tips of the fingers level with eyes. The Inside Side Seat is held for four (4) full strides.

Basic Scoring:

- Score of 10—A swing that lands lightly on the horse’s croup in a straight body plank position. Shoulder blades pulled together and head in line with torso and legs. Strength and tension are maintained throughout exercise. Legs are held together. Body lowers into Reverse seat with control. There is height and stretch during leg pass.—
- Score of 8—The swing lands lightly. Strength and tension are maintained but head is not in line. Legs are slightly separated. Return to reverse seat is not as stretched and controlled.—
- Score of 6—Swing lands lightly but body is not as tense and there’s some bend in hips. Legs are not completely together. Leg pass to inside seat has form but is lower than 45 degrees.—
- Score of 4—Swing into reverse plank does not land lightly onto croup. Shoulders are rounded and there is a break in the line at the hips. There is a constant lack of tension and security. Leg pass is lacking form and elevation.—
- Score of 10 - Vaulters maintains correct posture in inside side seat with arm out. The correct handle is held, and the arm is in the correct position. Legs are together and against horse. Correct absorption and harmony.
- Score of 8 – Minor deviation in posture, arm position, wrap, absorption and/or harmony.
- Score of 6 - Legs slightly apart but still against horse. Satisfactory harmony in seat.
- Score of 4 – Major deviation in form or posture. Major deviation in wrap, absorption and/or harmony. Stiff or lacking correct body tension.

Deductions –

- Up to -2 Points: For little to no swing into Box, Swing to Forward Plank and Reverse Plank-1 Point: Holding the incorrect handle in the side seat
- -2 Points: Incorrect arm position

REVERSE ONE LEG BENCH WITH QUARTER MILL DISMOUNT TO THE INSIDE

Essence: Harmony, balance, strength and posture

From inside side seat vaulter quarter mills to reverse seat, from reverse seat vaulter lifts leg and places foot on horse’s back for base of support (either leg may be used for support) and pushes up on leg to create a box underneath. The non-supporting leg is stretched and lifted up to form a vertical line perpendicular to the horse’s spine. There is nearly 90 degree angles between (1) the shoulders and torso, (2) the torso and raised leg, and (3) the knee angle of the supporting leg. A straight horizontal line through the shoulders, hip, and knee of the supporting leg. The Reverse One Leg Bench is held for four (4) full strides.

After exercise is held vaulter lowers themselves back to reverse seat astride in a controlled manner. Using the criteria as per the Quarter Mill, the vaulter mills from reverse seat to inside side seat. With closed legs, the vaulters turns to facing forward and stretches the arms and hips, then pushes against the handle(s) upwards and off the horse. The vaulter releases the handles and performs a correct landing.

Basic Scoring:

- Score of 10 – Correct posture, stability, harmony, form, control, and elevation of the leg.
- Score of 8 – Minor deviation of posture or stability shown by A brief loss of core tension or elevation of the leg during the exercise. Minor deviation of absorption leading to movement of the stretched leg.
- Score of 6 – The shoulder angle is less than 90 degrees which results in a medium break in the line from the shoulders, hips, and knee of the supporting leg. Medium deviation of control and/or stability.
- Score of 4 – The shoulder angle is markedly less than 90 degrees which results in a major break in the line from the shoulders, hips, and knee of the supporting leg. Major deviation in stability, absorption, and/or harmony.

Deductions -

- Up to -1 for deviations from described dismount to the inside.
- -1 point for not sitting reverse following the exercise.

APPENDIX D – CONSIDERATION OF THE BARREL

Consideration of the Barrel is the demonstration of the partnership between the vaulter and the horse (i.e. barrel) as shown on the Barrel. Work on the Barrel is considered to be preparation for work on the Horse, and exercises shown on the barrel should reflect exercises that would be shown at the vaulters level on the Horse.

Up to 10	<p>Weight: Elements are chosen that the horse can support and do not overload any space.</p> <p>Composition: All elements should be possible on the Horse.</p> <p>Balance: Elements are excellently balanced, controlled and centered over the Barrel.</p>
Up to 8	<p>Weight: Most elements can be supported by the horse and do not overload any space.</p> <p>Composition: All elements should be possible on the Horse.</p> <p>Balance: Elements are rarely off balance/uncontrolled and/or not centered over the Barrel.</p>
Up to 6	<p>Weight: Many elements can be supported by the horse and do not overload any space.</p> <p>Composition: One element is shown that may not be possible on the Horse.</p> <p>Balance: Elements are occasionally off balance/uncontrolled and/or not centered over the Barrel.</p>
Up to 4	<p>Weight: Some/few elements could be supported by the horse and some spaces are overloaded.</p> <p>Composition: Two or more elements are shown that may not be possible on the Horse. An element is shown that would cause a safety concern if a Horse was present (i.e. mounting over the barrels head).</p> <p>Balance: Many elements are off balance/uncontrolled and/or not centered over the Barrel.</p>

APPENDIX E – GENERAL IMPRESSION

General Impression encompasses the entry/exit, salute, and behavior of the vaulter(s) during the time they are in the competition arena.

Up to 10	<p>Entry, Exit, Salute: Vaulter(s) run in and run out with excellent energy, focus, and synchronization. Salute is clean and organized, with eye contact made with the judges.</p> <p>Presence: Vaulter(s) stand at attention and quietly at all times, including when standing in line.</p> <p>Turnout of Vaulter(s): Vaulter(s) attire and appearance are clean and tidy.</p>
----------	--

Up to 8	<p>Entry, Exit, Salute: Vaulters(s) run in and run out with good energy, focus, and synchronization. Salute is clean and organized, with eye contact made with the judges.</p> <p>Presence: Vaulters(s) stand at attention and quietly most of time, including when standing in line.</p> <p>Turnout of Vaulters(s): Vaulters(s) attire and appearance are clean and tidy.</p>
Up to 6	<p>Entry, Exit, Salute: Vaulters(s) run in and run out with moderate energy, focus, and some loss of synchronization. Eye contact is not maintained during the salute.</p> <p>Presence: Vaulters(s) stand at attention and quietly most of time, including when standing in line.</p> <p>Turnout of Vaulters(s): Vaulters(s) attire and appearance are mostly clean and tidy.</p>
Up to 4	<p>Entry, Exit, Salute: Vaulters(s) run in and run out with without energy, focus, or synchronization. Eye contact is never achieved during the salute.</p> <p>Presence: Vaulters(s) do not stand at attention and/or talk when standing in line.</p> <p>Turnout of Vaulters(s): Vaulters(s) attire and appearance is not clean and tidy.</p>

APPENDIX **DF** – TROT AND WALK HORSE SCORE

CHAPTER XVIII Trot and Walk Horse Score

Article 1801. Scoring for Guideline Horse Classes

1. Judged on:
 - a.

A1: Quality of Gait (40%)	
Rhythm	10%
Relaxation/Suppleness	10%
Connection	10%
Straightness	10%
A2: Vaultability of the Horse (45%)	
Willingness/Obedience	15%
Balance in Tempo	15%
Balance in Circling	15%
A3: Lunging (15%)	
Lunging	15%

- b. Horse penalties and deductions apply per EVUSA Rules Chapter V. Scoring.

2. A1: Quality of Gait - Trot/Walk

a. Trot/Walk Rhythm reference score

Reference Score	Description	Observation
Up to 10	Rhythm absolutely regular and expressed with energy. Length of strides equal throughout the performance. Hooves are clear of the ground during swing phase. TROT: Always clear 2 beat trot with clear moment of suspension. WALK: Always clear 4 beat walk with hind limb hooves tracking up to the front hoof prints.	<ul style="list-style-type: none"> · True rhythm of gait · Clear moment of suspension · Rhythm expressed with energy · Equal stride lengths · Footfalls always correct · Hind legs active · Horse in balance
Up to 8	Rhythm regular, expressed with moderate energy. Length of strides mostly equal throughout performance. Hooves are clear of the ground during swing phase. TROT: 2 beat trot with recognizable moment of suspension. WALK: 4 beat walk with hind limb hooves tracking up to the front hoof prints at least half of the time.	<ul style="list-style-type: none"> · Mostly true rhythm of gait · Suspension evident · Rhythm expressed with moderate energy · Footfalls mostly correct · Hind legs mostly active · Horse appears in balance
Up to 6	Rhythm mostly regular but lacking energy or rushing slightly. Length of strides somewhat variable throughout the performance. Hooves are clear of the ground during swing phase for most of the performance. TROT: 2 beat trot with moment of suspension no longer evident. WALK: 4 beat walk with hind limb hooves not tracking up to the front hoof prints.	<ul style="list-style-type: none"> · Changes in rhythm of gait · Not always clear 2 beat trot · Lacking energy or rushing slightly · Slight interruption of correct footfalls · Hind legs lacking activity causing rhythm faults · Horse mostly in balance
Up to 4	Rhythm mostly irregular and/or lacking energy and/or rushing. Length of strides vary throughout the performance. Hooves are not clear of the ground during swing phase for most of the performance, resulting in shuffling. TROT: 2 beat trot with moment of suspension no longer evident. WALK: 4 beat walk with hind limb hooves not tracking up to the front hoof prints.	<ul style="list-style-type: none"> · Rhythm of gait unclear at times · Rhythm lacking energy or rushing · Interruption of correct footfalls · Hind legs lacking activity vaulting severe rhythm faults · Horse rarely in balance
Up to 2	Rhythm irregular throughout the performance, length of stride is unclear throughout the performance. Hooves are not clear of the ground during swing phase for the entire performance, resulting in shuffling. TROT: 2 beat trot with no moment of suspension. WALK: 4 beat walk with hind limb hooves not tracking up to the front hoof prints.	<ul style="list-style-type: none"> · Rhythm of gait unclear · Correct footfalls not evident · Lack of energy · Hind legs severely lacking activity causing severe rhythm faults · Horse not in balance

b. Relaxation/Suppleness, Connection, and Straightness - Refer to the FEI Guidelines for Judges for reference scores.

3. A2: Vault Ability of the Horse - Trot/Walk

a. Refer to the FEI Guidelines for Judges for reference scores.

b. Deductions:

	Individual/Squad/PDD
--	-----------------------------

The horse is up to 4 strides in any gait other than defined by class.	1 point
The horse is more than 4 strides in any gait other than defined by class.	2 points
Medium interruptions: e.g., horse stalls or surges, crowhops, reacts to vaulter	1-2 points
Major interruptions: e.g., horse stops, bucks, leaps forward, turns around, moves backward	2-3 points

* A deduction is applied for each incidence. If multiple errors occur during one incidence, only one deduction is given for that incidence. Reason for deduction must be written on the scoresheet.

4. A3: Lunging - Trot/Walk
 - a. Refer to the FEI Guidelines for Judges for reference scores and deductions.

APPENDIX EG

JUDGES DISTRIBUTION

# of	Compulsories	Freestyle	Technical
1 judge	Scores all aspects	Scores all aspects	Scores all aspects
2 judges	Both judges do horse and compulsories	Judge A: Horse/Artistic (50%) Judge B: Technique (50%)	Judge A: Horse/Artistic (50%) Judge B: Technique (50%)
3 judges	Judge A: Horse (25%) Judge B: Exercises (37.5%) Judge C: Exercises (37.5%)	Judge A: Horse (25%) Judge B: Technique (50%) Judge C: Artistic (25%)	Judge A: Horse (25%) Judge B: Technique (50%) Judge C: Artistic (25%)
4 judges	Judge A: Horse (25%) Judge B: Exercises (25%) Judge C: Exercises (25%) Judge D: Exercises (25%)	Judge A: Horse (25%) Judge B: Technique (25%) Judge C: Artistic (25%) Judge D: Technique (25%)	Judge A: Horse (25%) Judge B: Technique (25%) Judge C: Artistic (25%) Judge D: Technique (25%)

EVUSA & USEF: If there is more than one judge, the President of the Ground Jury determines the distribution of judges based on Appendix E (above).

BARREL SPECIFICATIONS

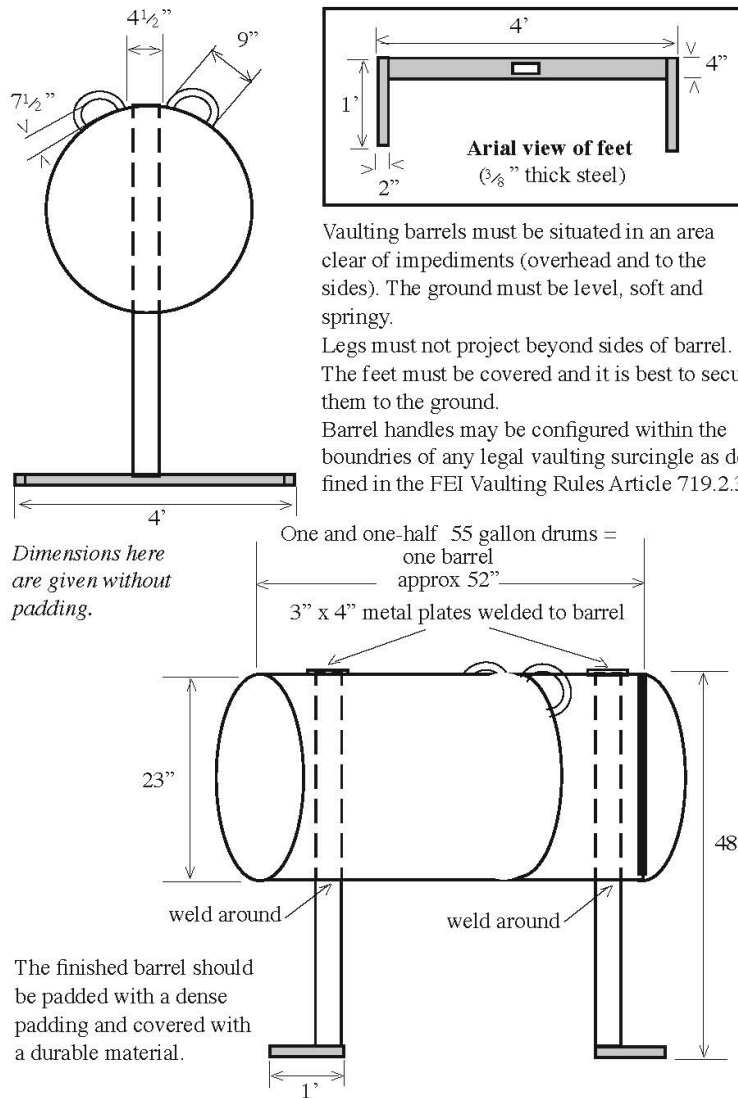

Dimensions here are given without padding.

Vaulting barrels must be situated in an area clear of impediments (overhead and to the sides). The ground must be level, soft and springy.
 Legs must not project beyond sides of barrel.
 The feet must be covered and it is best to secure them to the ground.
 Barrel handles may be configured within the boundaries of any legal vaulting surcingle as defined in the FEI Vaulting Rules Article 719.2.3

The finished barrel should be padded with a dense padding and covered with a durable material.

For questions about any barrel to be used for AVA recognized competition, please contact the Chair of the Technical Committee.